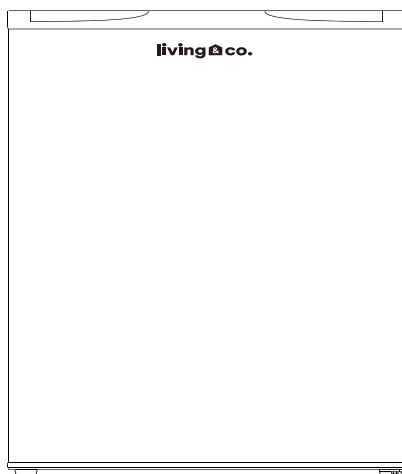




## Bar Fridge 41L



# INSTRUCTION MANUAL

MODEL: TWL41



# Contents

	Page
<b>1. Safety Instructions</b>	<b>02</b>
<b>2. Product Overview</b>	<b>05</b>
<b>3. Getting Started</b>	<b>06</b>
<b>4. Operating Instructions</b>	<b>08</b>
<b>5. FAQs &amp; Troubleshooting Guide</b>	<b>11</b>
<b>6. Other Useful Information</b>	<b>13</b>
<b>7. Warranty</b>	<b>20</b>

# 1. Safety Instructions

## IMPORTANT SAFETY INSTRUCTIONS READ CAREFULLY AND KEEP FOR FUTURE REFERENCE

**Read this manual thoroughly before first use**, even if you are familiar with this type of product. The safety precautions detailed will reduce the risk of fire, electric shock and injury when correctly adhered to. **Keep the manual in a safe place for future reference**, along with the completed warranty card, purchase receipt and carton. If applicable, pass these instructions on to the next owner of the appliance.



Pay particular attention to messages that follow this safety alert symbol or the words **DANGER**, **WARNING** or **CAUTION**. These words are used to alert you to a potential hazard that can seriously injure you and others. The instructions will tell you how to reduce the risk of injury and let you know what can happen if the instructions are not followed.



WARNING:  
Risk of fire

This symbol alerts you to take care as the appliance contains flammable materials: Isobutane as refrigerant and cyclopentane as insulation blowing gas. Do not expose it to high heat, sparks and open flames.

The refrigerant isobutane (R600a) is contained within the refrigerant circuit of the appliance, a gas with a high level of environmental compatibility, which is nevertheless flammable. During transportation and installation of the appliance, ensure that none of the components of the refrigerant circuit become damaged.

**WARNING: Do not damage the refrigerant circuit! Never use an appliance with a damaged refrigerant circuit!** If the refrigerant circuit becomes damaged, avoid proximity to open fires and all types of heat and ignition sources. Thoroughly ventilate the room in which the appliance is located.

It is hazardous for anyone other than an authorized service person to service this appliance.

### Responsible Disposal

At the end of its working life, do not dispose of this appliance with your household waste. Electrical and electronic products contain substances that can have a detrimental effect on the environment and human health if disposed of inappropriately. Observe any local regulations regarding the disposal of electrical consumer goods and dispose of it appropriately for recycling and recovery of the refrigerant and blowing agent.

**WARNING!** This refrigeration appliance contains flammable refrigerants and insulation blowing gases, which must be removed before disposal. Contact your local council for regulations concerning the disposal of such materials.

**DANGER!** Risk of child entrapment: When discarding this or another fridge, pull the plug out of the socket, cut the connection cable (as close to the appliance as you can) and remove the doors to prevent playing children to suffer electric shock or to get trapped inside the appliance.

To reduce the risk of fire, electric shock or injury, always follow basic safety precautions and accident prevention measures when using this appliance, including the following:

## 1.1 Electrical Safety

- **Voltage:** Plug the appliance in a 220-240V, 50Hz, properly earthed power outlet, which must be in good working order. Make sure your outlet voltage and circuit frequency correspond to the voltage stated on the appliance rating label.
- **Power connection:** Do not use an adaptor; do not use an extension cord. Plug the power plug directly into a separate power point that cannot easily be turned off accidentally, and that is easily accessible so you can switch it off when required.
- **Power cord:** Do not kink or damage the power supply cord. Do not leave it exposed or dangling. Secure it behind the appliance so no one steps on or places anything on the cord or against it. A squashed or damaged power plug may overheat and cause a fire.
- **Damaged cord:** Do not use a cord that shows cracks or abrasion damage along its length or at either end. Any damage to the cord may cause a short circuit, fire and/or electric shock. If the power cord is damaged, it must be replaced by the manufacturer or its service agent. Contact the after sales support line for advice.
- **Disconnection:** Never unplug the unit by pulling the cord. Always grip the plug firmly and pull straight out from the power point.
- **Electrical work:** All electrical work associated with the installation must be carried out by a licensed electrician.

## 1.2 Usage Conditions and Restrictions

- **Indoor domestic use only:** This appliance is intended for indoor domestic use only. It is not suitable for industrial or commercial use.
- **Intended purpose:** Do not use this appliance for anything other than its intended purpose, and only use it as described in this manual. Do not attempt to alter or modify this appliance in any way.
- **Usage restrictions:** This appliance is not intended for use by persons (including children) with reduced physical, sensory or mental capabilities, or lack of experience and knowledge, unless they have been given supervision or instruction concerning the use of the appliance by a person responsible for their safety.
- **Children:** Supervise children to ensure they do not play with the appliance. Close supervision is necessary when any appliance is used by or near children. Never allow children to operate, play with or crawl inside the appliance.
- **WARNING!** Do not use any **electrical appliances** (such as ice cream makers) inside refrigeration appliances, unless they are approved for this purpose by the manufacturer.

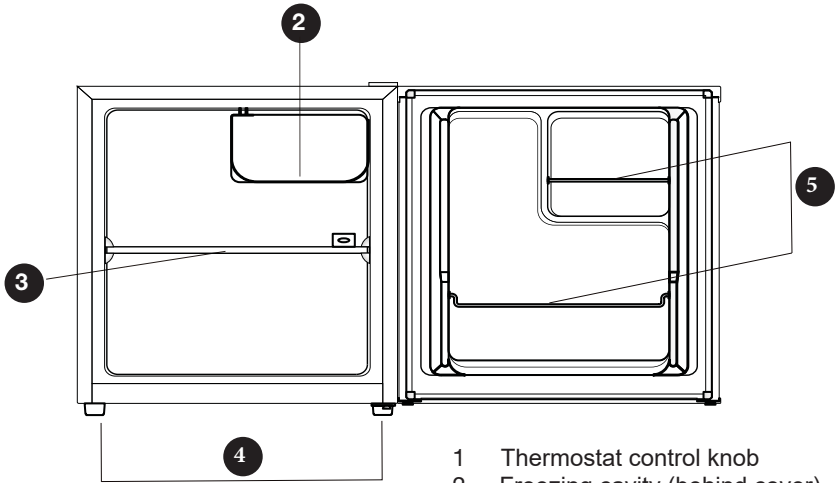
### 1.3 Cleaning and Maintenance

- **Disconnect:** Switch off and unplug the appliance from the mains socket before cleaning, maintenance or servicing. Failure to do so can result in electric shock, injury or death. Do not connect or disconnect the plug when your hands are wet.
- **Flames:** Do not let open flames or ignition sources enter the appliance.
- **Flammable/explosive substances:** Never clean this appliance with flammable fluids. Do not store or use volatile, flammable or explosive substances such as aerosol cans with flammable propellants in or close to this or any other appliance. The fumes can create a fire hazard or explosion.
- **Solvents:** Do not use solvent-based cleaning agents or abrasives on the interior as these may damage or discolor the surfaces of the appliances.
- **WARNING!** Do not use **mechanical devices** or other means to accelerate the defrosting process, other than those recommended by the manufacturer. Never use a sharp or metal instrument to remove frost or clean the fridge. Use a plastic scraper, if necessary.
- **Service:** Do not attempt to repair, modify or replace any part of the appliance unless specifically recommended in this manual. Refer all other servicing to a qualified technician, or contact the after sales support center for advice.

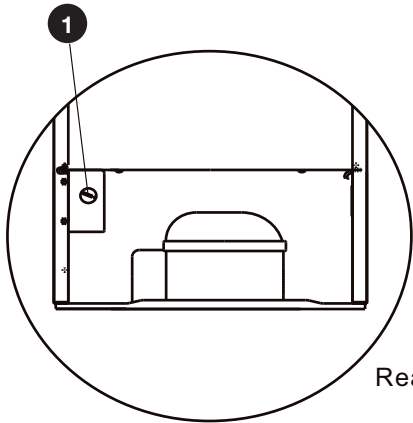
### 1.4 Installation

- **Heavy:** This appliance is heavy, take care when moving it. To avoid back or other injury, consider a two person lift or mechanical aid when installing it. Failure to do so can result in back or other injury.
- **Keep it upright:** Do not tilt the fridge more than 45° from upright when moving it.
- **Handle with care:** Do not apply force to any part such as the condenser or door.
- **WARNING:** Ventilation: To ensure proper ventilation, keep any ventilation openings, in the appliance enclosure or in the built-in structure, clear of obstructions. Ensure adequate air circulation around the appliance to prevent overheating.
- **Level:** Install the appliance level in order to ensure proper operation.
- **Location:** Install the appliance in an area that meets the following requirements:
- **Ambient temperature:** The air temperature surrounding the product must correspond to the climate class (T) indicated on the rating plate of the appliance: 16°C - 43°C.
- **Floor surface:** The floor must be sturdy, level (or nearly level) and strong enough to support the unit when it is fully loaded.
- **Areas to avoid:** Avoid areas where the appliance would be exposed to direct sunlight, sources of heat (stove, heater, radiator, etc.), extreme cold ambient temperatures or excessive moisture and high humidity (such as outdoors or exposed to wind, rain water spray or drips). Installing it in the coolest area of the room will save energy consumption and running costs.

## 2. Product Overview



- 1 Thermostat control knob
- 2 Freezing cavity (behind cover)
- 3 Shelf
- 4 Adjustable height feet
- 5 Door racks



Rear Side

**NOTE 1:** Due to continued product improvement, images and illustrations in this manual may vary slightly from the product purchased. All images in this manual are for reference purposes only. Parts are not necessarily pictured to scale.

**NOTE 2:** Your bar fridge has the capability of the door opening from the right or left side. If your setup requires reversal of the door swing, follow the instructions later in this manual.

## 3. Getting Started

### 3.1 Unpacking

- **Packaging materials:** This product has been packaged to protect it against transportation damage. Remove all packaging materials from around and inside the appliance and keep the original packaging carton and materials in a safe place. It will help prevent any damage if the product needs to be transported in the future, and you can use it to store the appliance when it is not in use. In the event that the carton is to be disposed of, please recycle all packaging materials where possible. Plastic wrapping can be a suffocation hazard for babies and young children, so ensure all packaging materials are out of their reach and disposed of safely.
- **Parts:** Check to ensure you have all the parts listed in the Product Overview section.
- **Damage:** When unpacking, check the appliance carefully for damage. If it is damaged, do not install the appliance. Contact our after sales support center for advice on examination or return of the damaged appliance.
- **Power cord:** Unwind the power cord to its full length and inspect it for damage. Do not use the appliance if the appliance or its cord have been damaged or are not working properly. In case of damage, contact our after sales support center for advice on examination, repair or return of the damaged product.
- **Read the manual:** Before installing your new fridge, read all safety instructions.
- **Clean:** Make sure the appliance is disconnected from the power supply before cleaning the interior. Remove any tape that secured drawers during transport. Clean the interior surfaces and all internal accessories with lukewarm water, a soft cloth and a neutral/mild soap/detergent. This will remove any dust from transit and storage and help remove the typical smell of a brand new product. Then dry thoroughly.  
**CAUTION:** Do not use harsh or abrasive detergents or powders as these will damage the finish.

### 3.2 Electrical Connection

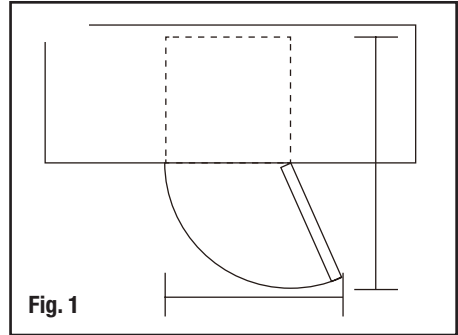
- **WARNING!** It must be possible to disconnect the appliance from the mains power supply; the plug must therefore be easily accessible after installation.
- **Before plugging in your new fridge, let it stand upright for at least 4 hours.** This will allow the refrigerant gases to settle into the compressor and reduce the possibility of a malfunction in the cooling system.
- The appliance must be earthed. The plug of the power supply cord is equipped with a contact for this purpose. Do not under any circumstances cut or remove the third (earth) prong from the power cord.
- Plug the unit into a dedicated, properly installed and earthed wall outlet. Ensure that your outlet voltage and circuit frequency correspond to the voltage stated on the appliance rating label.
- Secure the power supply cord behind the unit. Do not leave it exposed or dangling to prevent injury and accidental disconnection from the power supply.



## 3. Getting Started (Continued)

### 3.3 Space Requirements

- **Door opening:** Place the unit so there is enough space for the door to open easily (Fig. 1).
- **Clearances:** Ensure that air can circulate freely around the back of the cabinet, which is necessary to cool the compressor and condenser. Allow at least 5 cm clear space at the back and at the sides of the unit.

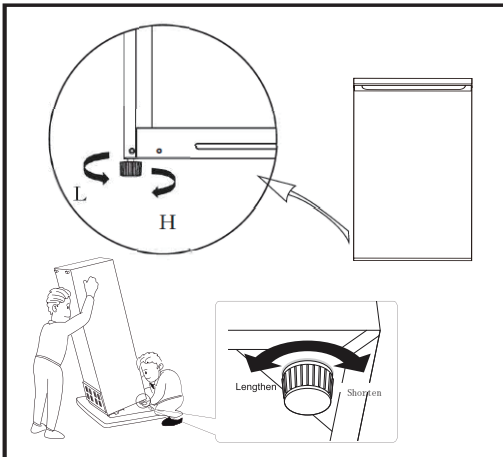


### Levelling

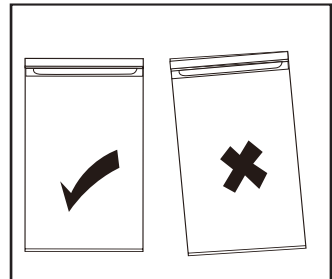
The appliance must be installed level in order to work properly. If the unit is not level, the doors and magnetic seal alignments won't align correctly. (Fig. 2).

- To level the unit, adjust one or both levelling feet at the front base of the cabinet (Fig. 3).

**Fig. 3**



**Fig. 2**

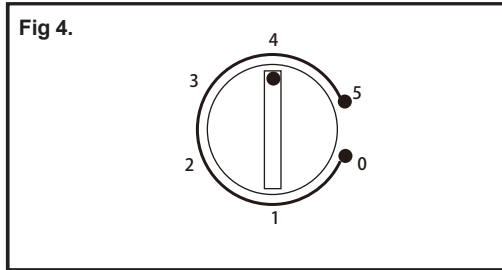


- To move the unit, tilt it slightly backward.
- To level the unit, adjust the leveling feet at the base of the cabinet.
- Turn the leveling feet clockwise to raise or anticlockwise to lower the front of the cabinet. Adjust as required to ensure that the cabinet is level.

## 4. Operating Instructions

### 4.1 Temperature control

- The thermostat control for regulating the temperature in the fridge is located on the rear cavity adjacent to the compressor. The dial can be adjusted from positions 0 - 5. Use a screwdriver / small coin or similar to rotate the inner dial (Fig. 4).



#### FIRST USE

- The first time you turn the unit on, set the temperature control to the coldest setting (5) for around 4 hours before you adjust the temperature to the setting that best suits your needs – a middle setting (3) should be appropriate in most cases for general operation.
- To turn the appliance off, first turn the temperature control to the minimum position (0), which will stop the cooling cycle, then disconnect the power supply cord from the wall outlet in order to shut off power to the unit.

#### NOTE:

- The unit may not work at the set temperature on particularly hot days, or if the door is opened too frequently. To ensure efficient operation, do not open the door unnecessarily or for prolonged periods of time.
- If the unit is unplugged, turned off or has lost power, you must wait 10 minutes before restarting it, otherwise the unit will not start.

### 4.2 Freezing compartment usage

- The freezer compartment is suitable for freezing ice cubes etc, it should not be packed full in order to allow for general circulation.

## 4. Operating Instructions (continued)

### 4.3 Freezing fresh foods

- Only freeze fresh food that is suitable for freezing.
- Do not store food uncovered in the freezer. Always use good quality, freezer-proof packaging to maintain food quality. Remove air from packages of solid food and seal bags tightly before freezing.
- Ensure that food placed in the freezer is dated and labelled. This will help you keep track of storage times.
- Keeping portions small will ensure they are frozen (and subsequently defrosted) rapidly.
- Make sure that fresh, unfrozen food packages do not touch food that is already frozen, thus avoiding a temperature rise in the frozen food.
- When freezing food, do not push food together too much, leave some space for air to circulate around each item. Do not place packages directly against the back wall.
- Do not place hot foods or liquids which may evaporate in the freezer compartment.
- When storing pre-packed, commercially frozen food, follow the food manufacturer's storage instructions. Do not exceed any storage times listed on the packaging.
- Once you have opened a packet of frozen food, rewrap it airtight to prevent surface evaporation which causes drying or freezer burn.
- Do not place carbonated liquids such as bottles of fizzy drink in the freezer as the container could explode under pressure and damage the freezer.
- Do not refreeze food once it has been defrosted. Frozen food which has thawed accidentally should either be used immediately or thrown away.

### 4.4 Power failure

- Most power failures are corrected within a few hours and should not affect the temperature inside your freezer, if you minimise the number of times the door is opened. However, if the power is going to be off for a longer period of time, you need to take proper steps to protect your food.

### 4.5 Going away?

- **Short vacation:** Leave the fridge operating during vacations of less than a month.
- **Long vacation:** If you are not going to use the fridge for longer periods, remove all food and unplug the power cord. Clean and dry the interior thoroughly. To prevent odour and mould growth, leave the door open slightly, blocking it open, if necessary.

## 4. Operating Instructions (continued)

### 4.6 Energy saving tips

- Locate the fridge in the coolest area of the room, away from heat-producing appliances and out of direct sunlight.
- Let hot foods cool to room temperature before placing them in the fridge. Overloading the fridge forces the compressor to run longer.
- Wrap foods properly and wipe containers dry before placing them in the fridge. This cuts down on frost build-up inside the unit.
- Do not line the fridge storage drawers with aluminium foil, wax paper or paper towelling. Liners interfere with cold air circulation, making the fridge less efficient.
- Do not pack food packages close together as this prevents air circulating.
- Organise and label food to reduce door openings and extended searches. Remove as many items as needed at one time and close the door as soon as possible.
- Do not open the fridge door unnecessarily or for too long, especially during a power failure.
- Do not run the appliance permanently on the MAX temperature setting (5). The highest setting is recommended on very hot days, or for temporary use when you have added a large quantity of fresh food.

### 4.7 Moving the fridge

- Remove all food from inside the fridge, securely tape down the drawer and shelves and tape the door shut. Turn the levelling feet up to the base to avoid damage.
- Protect the outside of the unit with a blanket or similar soft material and make sure the fridge stays secure in the upright position during transportation.
- Remove all food from inside the fridge, securely tape down the drawer and tape the door shut. Turn the levelling feet up to the base to avoid damage.

### 4.8 Storage

- If the fridge is not going to be used for an extended period of time, store the unplugged, cleaned appliance safely in the original packaging in a dry location. Leave the door ajar for several days to ensure any moisture is removed. Do not leave door closed with moisture present as this can lead to mould forming on internal surfaces.

## 5. FAQs & Troubleshooting Guide

If you experience a problem with your fridge, check in the following table for solutions to help you solve the problem before you call customer service.

Problem	Possible cause
The appliance does not operate.	<ul style="list-style-type: none"> <li>• It is not plugged in. Ensure it is correctly plugged in and there is power at the socket (plug another appliance into the outlet to check).</li> <li>• The circuit breaker tripped or has blown a fuse.</li> <li>• The fridge temperature control is set too warm.</li> <li>• A general power outage has cut power to your home (check the household lights).</li> </ul>
The compressor turns on and off frequently.	<ul style="list-style-type: none"> <li>• The room temperature is hotter than normal.</li> <li>• A large amount of food has been added to the fridge.</li> <li>• The fridge door is opened too often, or not closed completely.</li> <li>• The temperature control is not set correctly.</li> <li>• The door gasket does not seal properly. Check and ensure the door is properly aligned.</li> <li>• The appliance does not have the correct clearances around it for air circulation.</li> </ul>
The appliance seems to make unusual noises.	<ul style="list-style-type: none"> <li>• A rattling noise may come from the flow of the refrigerant, which is normal.</li> <li>• As each cycle ends, you may hear gurgling sounds caused by the flow of refrigerant.</li> <li>• Contraction and expansion of the inside walls may cause popping and crackling noises.</li> <li>• The appliance is not level. Readjust the feet.</li> <li>• The appliance is touching the wall or other object. Move it slightly.</li> </ul>
The door will not close properly.	<ul style="list-style-type: none"> <li>• The appliance is not level.</li> <li>• The door was reversed and is not correctly installed.</li> <li>• The door gasket is dirty or bent.</li> <li>• The drawers are out of position.</li> </ul>
The appliance door will not open.	<ul style="list-style-type: none"> <li>• If the door has just been opened, leave it for a few seconds to allow the air pressure to equalise before trying again.</li> </ul>

## 5. FAQs & Troubleshooting Guide (Continued)

Food is not cold enough	<ul style="list-style-type: none"><li>• Reset the temperature to a colder setting.</li><li>• Make sure the door is only opened for as long as is necessary. Do not keep it open for an extended period.</li><li>• If you have added a large quantity of warm food in the appliance within the last 24 hours, turn the temperature control to a colder setting temporarily.</li></ul>
Food freezes too much	<ul style="list-style-type: none"><li>• Adjust the temperature control to select a warmer setting.</li></ul>
The external fridge surfaces are warm	<ul style="list-style-type: none"><li>• The exterior fridge walls (side panels) can be warmer than room temperature. This is normal while the compressor works to transfer heat from inside the fridge cabinet.</li></ul>
Excessive frost and ice has built up	<ul style="list-style-type: none"><li>• Ensure the door is not left open.</li><li>• Check that nothing is preventing the door from closing.</li><li>• Check that the door gasket is intact and clean.</li><li>• This can occur if heated food items are placed directly in the fridge.</li><li>• Ensure the fridge is defrosted periodically.</li></ul>

## 6. Other Useful Information

### WARNING!

To reduce the risk of electric shock or injury, always switch off the appliance and disconnect it from the power supply before cleaning or maintenance.

### 6.1 Cleaning the fridge

- For hygienic reasons the appliance interior surfaces and accessories should be cleaned regularly. We recommend cleaning the fridge after defrosting it, while all frozen food and drawers are already removed from the compartment. Make sure the fridge is unplugged from the power supply, the temperature control is set to MIN and all food and storage drawers are removed.
- Wash the inside surfaces and the interior accessories with a damp, warm cloth moistened in a water and baking soda solution (about 2 tablespoons of baking soda to 1 litre of water). Wring excess water out of the cloth before cleaning around the temperature control or any electrical parts. Rinse and wipe dry with a soft cloth.
- Clean the outside of the unit with a damp, well wrung out cloth. Keep the door gasket (seal) clean.
- After everything is dry, place appliance back into service.

### WARNING!

- Never clean the unit with an abrasive, acid, oil or solvent based cleaning agent, or with abrasive pads or scourers. Never use flammable fluids or sprays for cleaning as the fumes from these substances can create a fire hazard or explosion.
- Never clean the appliance with a steam cleaner. Moisture could accumulate in the electrical components, danger of electric shock! Hot vapours can lead to the damage of plastic parts.
- The appliance must be completely dry before it is placed back into service.
- Ethereal oils and organic solvents can attack plastic parts, e.g. lemon juice or the juice from orange peel, butyric acid, or cleansers that contain acetic acid. Do not allow such substances to come into contact with the appliance parts.

### 6.2 Defrosting the freezing compartment

- For efficient operation and minimum energy consumption, defrost the freezer when the frost on the freezer walls is building up; do not let it build up to more than 3–4mm thick.
- Turn the temperature control to the MIN position (0), unplug the fridge and remove the food and storage drawers. (Keep any frozen food temporarily in a fridge or cooler bag to keep defrosting to a minimum.)
- Keep the door open and place a tray and old towel underneath the freezer to collect the defrost water. Discard the defrost water and clean the freezer as described above.
- **CAUTION:** Never use sharp or metallic tools to scrape off the ice from the evaporator or wall surfaces. Do not use boiling water to accelerate defrosting as this may cause damage to plastic parts.

## 6. Other Useful Information (Continued)

### 6.3 Door reversal

This appliance has the capability of opening the door from either the left or right side. If your set-up requires changing the opening direction, proceed as follow:

#### IMPORTANT!

##### You will need:

- Make sure you have someone there to help you, do not try to do this on your own.
- It will be necessary to tilt the unit back when taking the door off. You should rest the unit on something solid so that it will not slip during the door reversal process.
- Have some soft foam packaging or similar material (blanket or towel) ready to lay the appliance door on. Do not lay the unit flat as this may damage the coolant system.
- You will need a flat-bladed screwdriver, a Phillips head screwdriver and a hexagonal spanner (not supplied).

##### Before you begin:

- Unplug the appliance from the mains electricity supply (if connected).
- Empty all food and drawers out of the appliance (if applicable).
- Adjust the levelling legs to their highest level.
- Keep all parts you remove for re-installation of the door on the other side.

1. Remove the hinge cover by carefully prising it off with a flat bade screwdriver.(Fig. 5).
2. Open the door and unscrew the top hinge (Fig. 6). Then take the door off the cabinet and place it in a safe position where it will not get damaged. Keep the screws for reuse on the other side.

Fig. 5

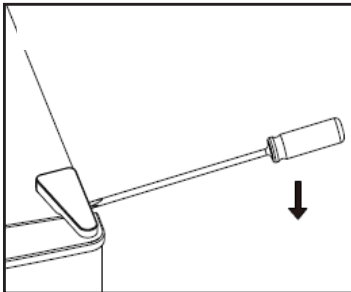
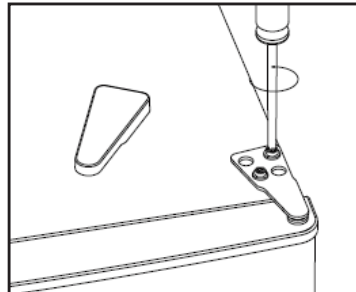


Fig. 6

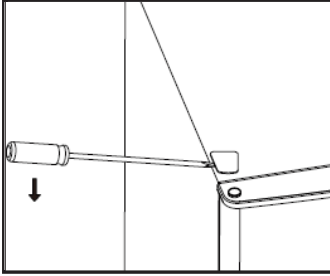




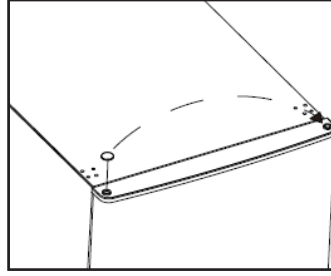
## Door reversal (continued)

3. Remove the screw cover at the left side (Fig. 7).
4. Move the support hole cover from the left to the right side (Fig. 8).

**Fig. 7**

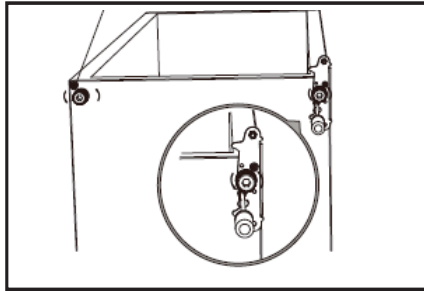


**Fig. 8**



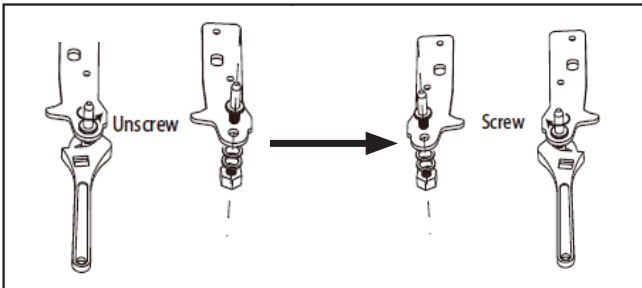
5. Unscrew the bottom hinge and remove the adjustable feet from both sides (Fig. 9).

**Fig. 9**



6. Unscrew and remove the bottom hinge pin. Then turn the bracket over and replace it. (Fig 10).

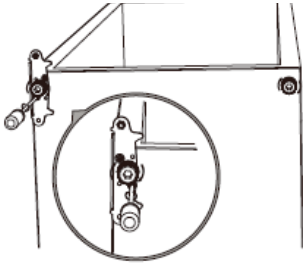
**Fig. 10**



## Door reversal (continued)

7. Refit the bracket for the bottom hinge pin (Fig. 11). Replace both adjustable feet.

Fig. 11



8. Place the door back onto the fridge. Ensure it is aligned horizontally and vertically aligned, so that the seal is snug on all sides.
9. Once this is done, insert the hinge bracket and screw it to the top of the unit (Fig. 12). Use a wrench to tighten it, if necessary.
10. Finally, reattach the hinge cover and screw cover (Fig. 13).

Fig. 12

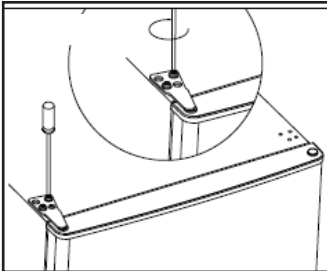
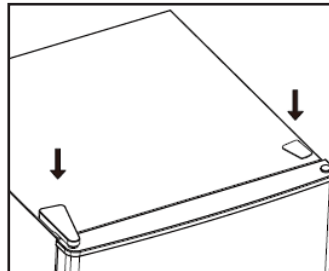


Fig. 13



## 6. Other Useful Information (Continued)

### 6.4 Service and repair

Do not attempt to alter or modify this appliance in any way. Do not attempt to repair or replace any part of the appliance unless it is specifically recommended in this manual. All other servicing should be referred to a qualified technician and only genuine spare parts must be used.

### 6.5 Technical specifications

Model	VY Š41
Rated voltage	220–240 V~
Rated frequency	50 Hz
Rated current	0.55 A
Climate class	T
Electrical protection class	I
Refrigerant	R600a (12.5 grams)
Insulation blowing agent	Cyclopentane
Storage volume	41 L
Dimensions	440 (W) x 475 (D) x 515 (H) mm

### Compliance

This product has been fully tested and meets all requirements as set out by standards AS/NZS 60335.1 and AS/NZS 60335.2.24.



E2198

**T** This marking indicates that the appliance is suitable for use in tropical climates under ambient temperatures of 16 °C to 43 °C.

### 6.6 Responsible Disposal

At the end of its working life, do not dispose of this appliance with your household waste. Electrical and electronic products contain substances that can have a detrimental effect on the environment and human health if disposed of inappropriately. Observe any local regulations regarding the disposal of electrical consumer goods and dispose of it appropriately for recycling and recovery of the refrigerant and blowing agent.

**WARNING!** This refrigeration appliance contains flammable refrigerants and insulation blowing gases, which must be removed before disposal.

**DANGER! Risk of child entrapment:** When discarding this or another fridge, pull the plug out of the socket, cut the connection cable (as close to the appliance as you can) and remove the doors to prevent playing children to suffer electric shock or to get trapped inside the appliance.

## 7. Warranty



# living & co.

### Warranty

We pride ourselves on producing a range of quality products that are both packed with features and completely reliable. We are so confident in our products, we back them up with a two years warranty.

Now you too can relax knowing that you are covered.

Customer Helpline NZ: 0800 422 274

This product is covered by two years warranty when accompanied by proof of purchase.