



Read the manual

It will help you get the best out of your product.
Still have questions?
Call After Sales Support

0800 422 274

living & co.

Warranty

We pride ourselves on producing a range of quality home appliances that are both packed with features and completely reliable. We are so confident in our products, we back them up with a 1 year warranty.

Now you too can relax knowing that you are covered.

Customer Helpline NZ:0800 422 274

This Product is covered a 1 year warranty when accompanied by proof of purchase.

living & co.

AROMA DIFFUSER



INSTRUCTION MANUAL

MODEL: PR-321M

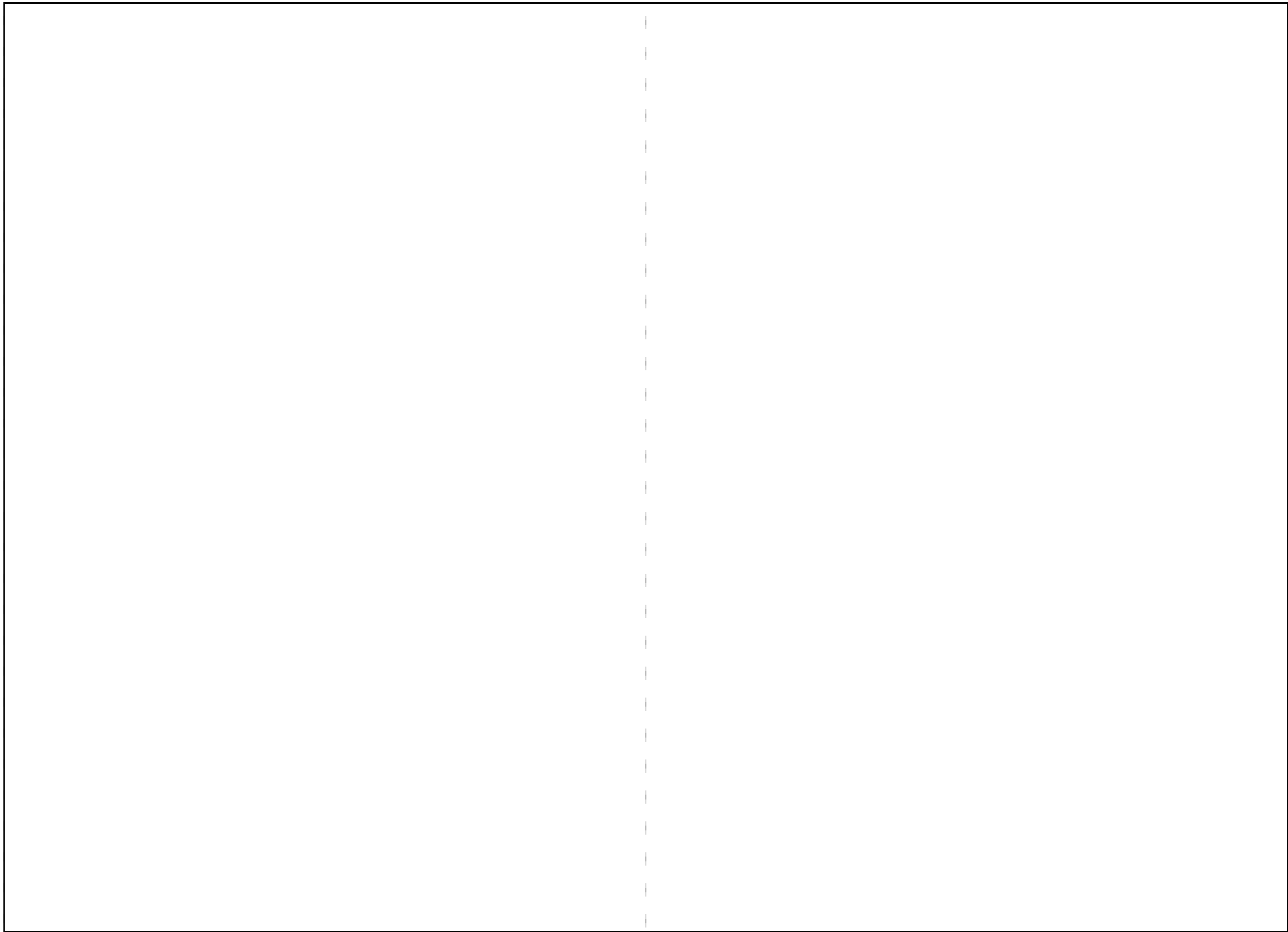

ATTENTION

Product maintenance

1. Turn off the machine and unplug the power supply.
2. Take off the cover and pour out water from the atomizing chamber in the direction of the "MAX" marking.
3. Wipe the cover and water tank with a soft cotton cloth.
4. Wipe the center of the tank gently with a cotton swab. It is recommended to be wiped every 7 to 14 days.

Common faults

Faults	Cause	Processing method
	No power	Connect the power supply, press the "⏻" button
	Not enough water	Add water to the atomizing chamber
No vapour	Too much water	Pour water out from the atomizing chamber
	Atomizer is covered by dirt.	Clean the dirt on the atomizer.
	Cover is blocked by foreign objects	Use cotton to wipe and keep clean

Use requirements

1. This product is suitable for use with clean water or pure water; it is not suitable for use with corrosive liquid.
2. If the product is not carefully operated, the water may leak into the inner enclosure. If so, please unplug the power supply immediately, pour out the water, clean the body and let stand for about 3 days in a ventilated place. Let it dry naturally. If there is any other abnormal occurrence, please contact customer service.

Contents

PRODUCT OVERVIEW	2
OPERATING INSTRUCTIONS	3
ATTENTION	4

PRODUCT OVERVIEW

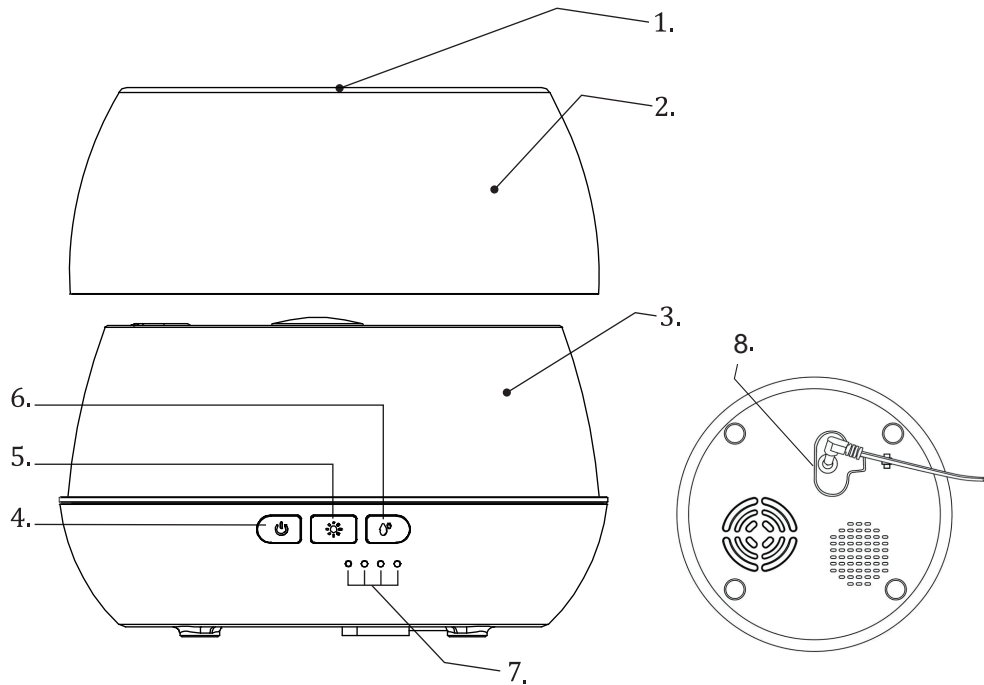

- | | |
|---|--|
| 1. Water vapor outlet | 4. ON / OFF / TIMER Button (Subsequent presses) |
| 2. Removable Cover | 5. LIGHT Button (Subsequent presses to alternate colour) |
| 3. Atomizing chamber | 6. Low / High Mist Mode |
| 7. ON / Timer status indicators (ON continuous / 10 seconds alternating on-off / 2 Hours On / 4 Hours On) | |
| 8. Adaptor power lead connection socket. | |

Specifications:

Model: PR-321M
Run time: 12 Hours
Power: 8W

Output voltage: DC 24V8W
Input voltage: AC 100-240V 50/60Hz
Dimensions: 168x168x120mm
Ultrasonic frequency: 2.4MHz

OPERATING INSTRUCTIONS

1. Lift the cover in the direction shown by the arrow.

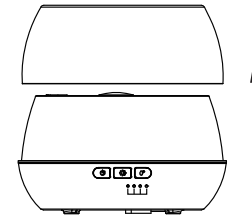

2. Add water to the atomizing chamber do not exceed Max line

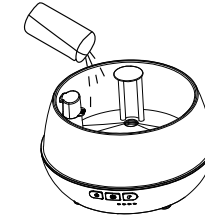

3. Return the cover in this direction.

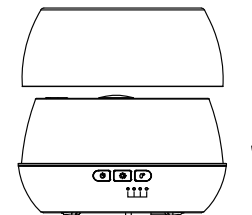

4. Connect the power supply shown by the arrow.

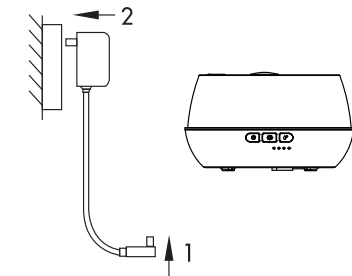

How to add aromatherapy oil:

Turn off the power supply, remove the cover, and add the aromatherapy oil you choose to the atomizing chamber, then add a suitable amount of water. Cover the lid and turn on the power.

Caution:

When adding water to the tank, please add the correct amount and never exceed the Max scale mark. The maximum capacity is 500ml. Do not move the diffuser in use, and keep it far away from places children can access.

Note:

If you add too much water at first, there will be less water vapor produced. As the amount of water decreases, the vapor will increase.