

living & co.

DEHUMIDIFIER



INSTRUCTION MANUAL MODEL DYD-Y20A

Thank you for choosing this product.
Please read this instruction manual before using it.

AFTER SALES SUPPORT

  0800 422 274



Read the USER MANUAL carefully before operation.



Further information is available in the USER MANUAL, SERVICE MANUAL, and the like.



Service personnel are required to carefully read the USER MANUAL and SERVICE MANUAL before operation.



Recycle unwanted materials instead of disposing of them. All appliances and packaging should be sorted and tendered at a regional recycling centre and be processed in an ecological manner.



This unit uses a flammable refrigerant.
If refrigerant leaks and comes in contact with fire or heating part, it will create harmful gas and there is risk of fire.

Product Overview

Figure 1

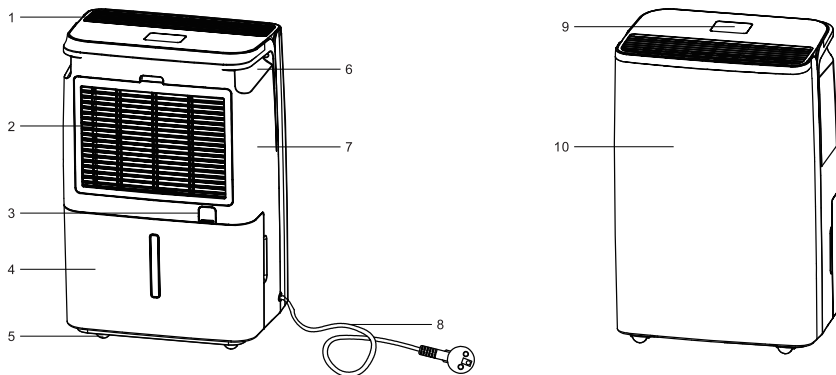

Figure 2

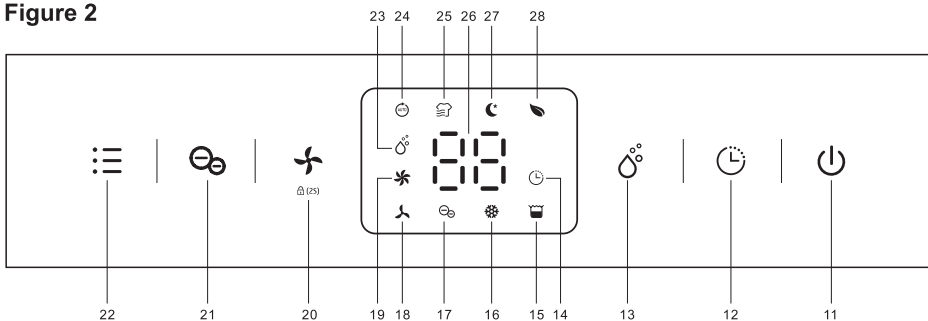
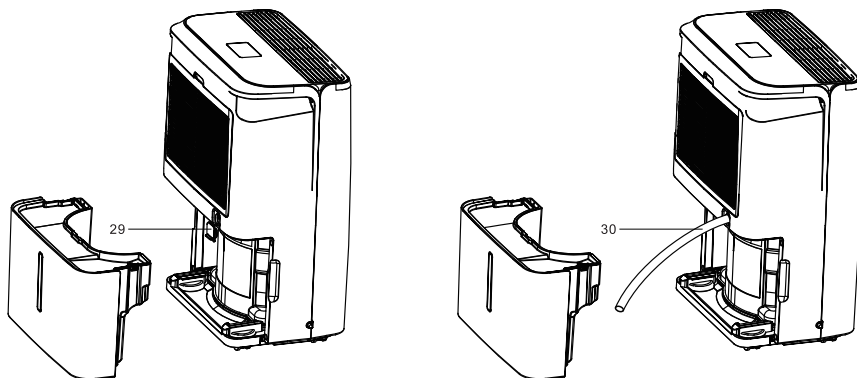

Figure 3



Product Description

Components

1. Air Outlet
2. Air Inlet Grille
3. Continuous Drainage Outlet
4. Water Tank
5. Castor wheels
6. Handle
7. Rear Cover
8. Power Cord
9. Control Panel
10. Front Cover

Control Panel

11. Power Button (On / OFF)
12. Timer Off Button
13. Manual Dehumidifying Button
14. Timer Indicator
15. Tank Full Indicator
16. Defrost Indicator
17. Air Ioniser indicator
18. Low Fan Speed Indicator
19. High Fan speed indicator
20. Fan Speed Button / Child Lock Button
21. Air Ioniser Button
22. Mode Button
23. Manual Dehumidifying Indicator
24. Auto Indicator
25. Laundry Drying Indicator
26. Humidity Display
27. Sleep Indicator
28. Air Filtering Indicator

Drainage

29. Drainage Outlet Plug
30. Drainage hose

Table of Contents

Product Instructions	5
Safety Instructions	5-6
Prior to Operation	8
Continuous Drainage	8
Operation Instructions	9-13
Cleaning	14
Storage	15
Display Error Codes	15
Safety Precautions On Servicing	16-17
Trouble Shooting	18
Technical Specifications	19

Product Instructions

The dehumidifier is used to remove excessive moisture from the air. The resulting reduction in relative humidity protects buildings and their contents from the adverse effects of excess humidity.

The environmentally friendly R290 is used as the refrigerant. R290 has no damaging influence on the ozone layer (ODP), a negligible greenhouse effect (GWP) and is available worldwide. Because of its efficient energy properties, R290 is highly suitable as a coolant for this application. Special precautions must be taken into consideration due to the coolant's high flammability.

Safety Instructions

- This appliance can be used by children aged from 8 years and above and persons with reduced physical, sensory or mental capabilities or lack of experience and knowledge if they have been given supervision or instruction concerning use of the appliance in a safe way and understand the hazards involved. Children shall not play with the appliance. Cleaning and user maintenance shall not be made by children without supervision.
- The unit is designed only for use with R-290 (propane) gas as the designated refrigerant.
- **THE REFRIGERANT LOOP IS SEALED. ONLY A QUALIFIED TECHNICIAN SHOULD ATTEMPT TO SERVICE!**
- Do not discharge the refrigerant into the atmosphere.
- R-290 (propane) is flammable and heavier than air.
- It collects first in low areas but can be circulated by the fans.
- If propane gas is present or even suspected, do not allow untrained personnel to attempt to find the cause.
- The propane gas used in the unit has no odor.
- The lack of smell does not indicate a lack of escaped gas.
- If a leak is detected, immediately evacuate all persons from the store, ventilate the room and contact the local fire department to advise them that a propane leak has occurred.
- Do not let any persons back into the store until the qualified service technician has arrived and that technician advises that it is safe to return to the store.
- No open flames, cigarettes or other possible sources of ignition should be used in the vicinity.
- Component parts are designed for propane and non-incentive and non-sparking. Component parts shall only be replaced with identical repair parts.
- If the supply cord is damaged, it must be replaced by the manufacturer, its service agent or similarly qualified persons in order to avoid a hazard.
- The appliance shall be disconnected from its power source during maintenance.
- Ensure the unit is far away from fire, inflammable, or explosive objects.
- Do not use means to accelerate the defrosting process or to clean, other than those recommended by the manufacture.

Safety Instructions

- The appliance shall be stored in a room without continuously operation sources (for example: open flames, an operating gas appliance or an operating electric heater).
- The appliance shall be stored so as to prevent mechanical damage from occurring.
- Do not piece or burn, even after use.
- Pipe-work shall be protected from physical damage and shall not be installed in an unventilated space, if that space is smaller than 8 m².
- Compliance with national gas regulations shall be observed.
- Keep any required ventilation openings clear of obstruction.
- The appliance shall be stored in a well-ventilated area where the room size corresponds to the room area as specified for operation.

Warning

- Failure to abide by this warning could result in an explosion, death, injury and property damage.
- Any person who is involved with working on or breaking into a refrigerant circuit should hold a current valid certificate from an industry-accredited assessment authority, which authorizes their competence to handle refrigerants safely in accordance with an industry, recognized assessment specification.
- Servicing shall only be performed as recommended by the equipment manufacturer. Maintenance and repair requiring the assistance of other skilled personnel shall be carried out under the supervision of the person competent in the use of flammable refrigerants.

Prior to Operation

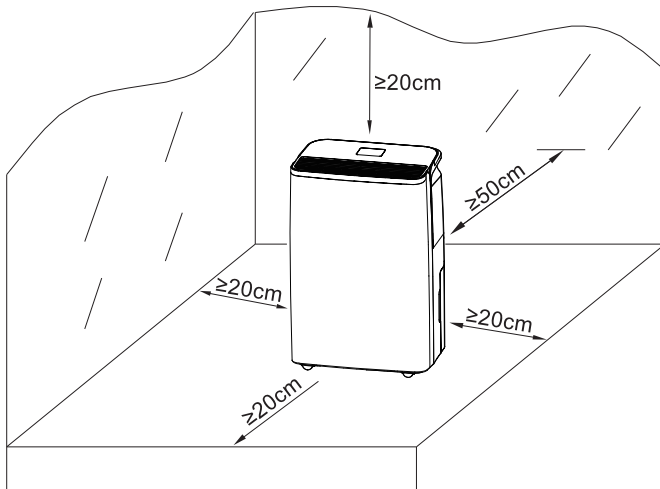

- Place the dehumidifier in an upright position on a stable, flat surface.
- Ensure the dehumidifier is at a safe distance at least 50cm away from a wall or furniture.
- Supply power should be in correspondence with the value on the nameplate, power outlet needs to be grounded.
- Ensure the tank is correctly fitted, if the tank is full or not in place, the tank full light comes on and the dehumidifier will stop working.
- Turn on the power and run the machine as per instructions below.

Continuous Drainage

In normal use, water will be collected by the integrated tank, if you want to set up continuous drainage to allow water to discharge via the outlet hose, please follow the steps as below (refer to figure 3)

1. Unplug the drainage outlet plug.
2. Insert the drainage hose (provided) into the drainage outlet.

Note: always make sure the hose is positioned on a decline (sloping downwards), is not blocked or kinked.

Operation Instructions

🗨️ Connect the power plug to a socket outlet and switch on; the unit will emit a “beeping” sound.

Switch On / Switch Off The Unit [Power button]

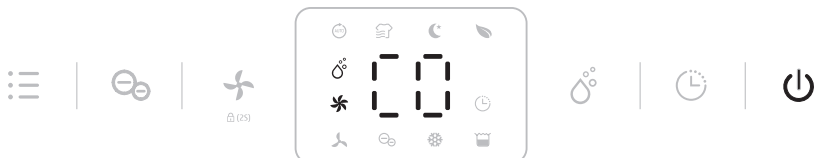

Press the power button once to turn on the unit, the unit runs on default mode for manual continuous dehumidifying with high fan speed.

🗨️ Press the power button to turn off the unit, it will stop working, fan will continue for a few seconds to blow out the hot air inside the unit.

Auto Shut-off Timer Function [Timer button]



🗨️ Press the timer button to select your preferred timer in hours from 00h-24h-00h : each press will allow timer to cycle from 0 - 24 hours. Once the desired setting has been set, allow 2 seconds for the display to stop flashing and the timer will be set.

🗨️ Auto timer off setting will be canceled if you switch the unit off and switch on again.

Manual Dehumidifying Mode [Manual button]

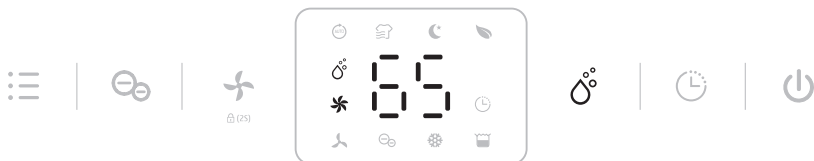

Press the manual button to select your preferred humidity from CO-30%-35%-40%-45%-50%-55%-60%-65%-70%-75%-80%-CO. CO means continuous dehumidifying regardless of ambient humidity.

🗨️ In manual mode, all buttons are selectable.

AFTER SALES SUPPORT

📞 (NZ) 0800 422 274

living & co. 9

Operation Instructions

Fan Speed Option [Fan Speed button]



Press the fan speed button to select your preferred fan speed setting of low and high to meet the different usage requirements.

⚠ Fan speed variation is not selectable in laundry drying mode, auto mode or defrost mode.

Air Ioniser Function [Ioniser button]

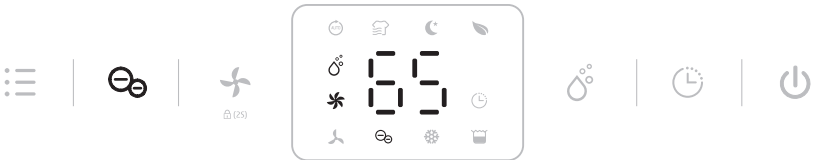

Press the Ioniser button to activate the Ioniser function. This function activates a negative ion generator to help collect air pollutants and improving air quality.

⚠ Ioniser function will switch off automatically when the fan switches off.

Multifunction Option [Mode button]

• Auto Dehumidifying Mode

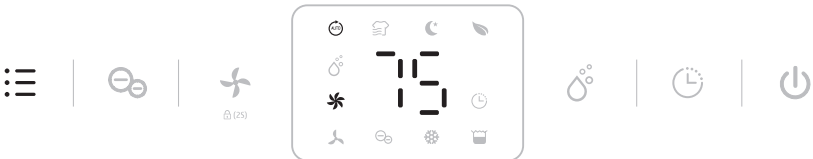

Press the mode button once to select the auto dehumidifying mode, the unit runs automatically accordance to the ambient humidity detected below.

Ambient RH% detected	Compressor	Fan Speed Level
RH% > 65%	Working	High
55 ≤ RH% ≤ 65	Working	Low
RH% < 55%	Stop working	Low

Operation Instructions

Multifunction Option [Mode button]

• Laundry Drying Mode

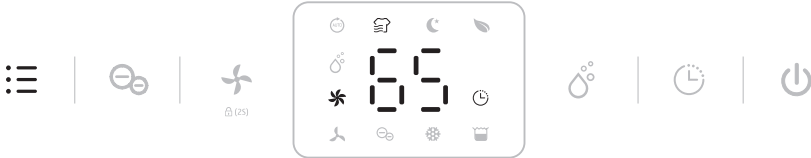

Press the mode button twice to select Laundry Drying mode, the unit runs in continuous dehumidification with high fan speed for 6 hours then switches off automatically.

💬 Fan speed option and Timer functions are not selectable in this mode.

• Sleep Mode

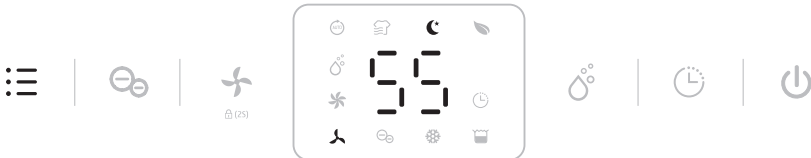

Press the mode button 3 times to select Sleep mode, the unit runs with a designated humidity setting of 55% along with low fan speed. All indicators will be off 5s after the setting is completed. Touch any button to activate display screen, and to operate as usual.

💬 Fan speed button is not selectable in this mode.

💬 If no buttons are pressed for 30 seconds, the display screen will switch off, press any button to reactivate the display.

💬 When the water tank is full on sleep mode, water tank full indicator will always be on.

• Air Filtering Mode

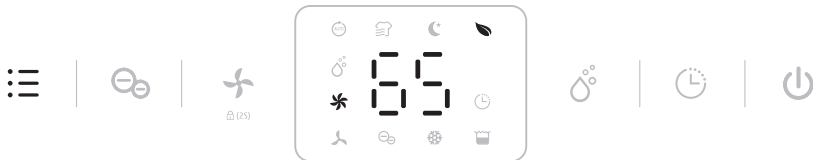

Press the mode button 4 times to select Air Filtering mode, the unit runs with high fan speed without dehumidifying.

Operation Instructions

Safety Childlock Function [Fan Speed button- hold for 2 seconds]



Press and hold the fan speed button for 2s to lock all the buttons, the same operation will unlock it. When set, no buttons will be function when pressed.

💬 Safety childlock function can be set at standby mode and in operational mode.

Low Temperature Defrost Mode



When the ambient temperature is too low, the dehumidifier will enter into the defrost mode, the unit operates with high fan speed without dehumidifying.

💬 Fan speed button is not selectable.

Auto Shut off with Water Tank Full Indicator

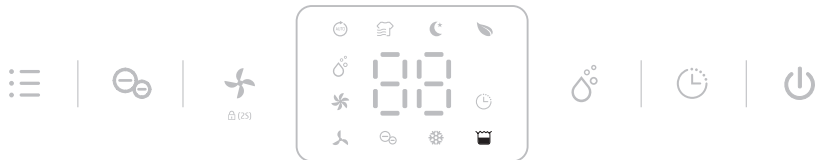

The unit will go into standby mode when water tank is full or the water tank is not installed properly. After emptying the tank or correctly fitting the water tank the unit will resume normal operation.

💬 Except for the power button, all other buttons are not selectable when the tank is full.

Operation Instructions

Memory Function:

- a. When unplugged directly or if the power is cut, then reconnected, the dehumidifier will return to the mode operating prior to the shutdown. The timer setting will be maintained.
- b. If you press the power button to switch off the dehumidifier, and then press the power button to switch it back on. The dehumidifier will run with the mode prior to the shutdown. The timer setting will be canceled.
- c. If you switch off the dehumidifier and unplug the power cord, then reconnect the power supply and switch on the dehumidifier. It will run as per factory preset mode the first time you operated.

Cleaning

When used regularly, the filter may become clogged with dust and particles. Therefore the filter should be cleaned at least every two weeks. Follow these steps:

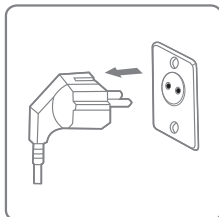

1. Switch the device off and remove the plug from the socket before cleaning.

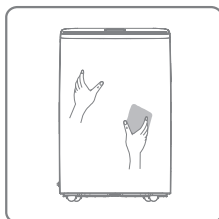

2. Clean the housing with soft, dry cloth. If the device is extremely dirty, use a mild cleaning agent. Wipe the dehumidifier with a slightly damp cloth. Never spray the device with water.

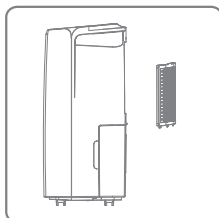

3. Remove the filter, clean the filter with a vacuum cleaner or soapy water no hotter than 40°C.

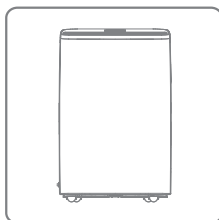

4. Rinse and dry the filter completely before installing back to the device.

Storage

If the dehumidifier will not be used for a long period of time, take the following steps:

1. Remove the plug from the socket and empty the tank, allow the tank and the dehumidifier to dry completely. Place in a warm location with some airflow, but out of direct sunlight. This may take a day to fully dry out.
2. Clean the air filter.
3. Check the dehumidifier for damage.
4. Store the dehumidifier in a dust-free and out of direct sunlight location, preferably covered with a towel or stored in the original packaging box.

Display Error Codes

Display Code	E1	E2	L3	L4
Error	Temperature sensor error	Humidity sensor error	Air inlet temperature is too high >42°C	Air inlet temperature is too low <0°C
Display	Flash every 30 seconds	Flash every 30 seconds	Slowly flash L3	Slowly flash L4
What is happening	Machine works normally but has a component fault with the temperature sensor, contact the supplier for repair.	Machine works normally but has a component fault with the humidity sensor, contact the supplier for repair.	Compressor stops working, fan works at low fan speed. 10mins later, if the temperature decrease to below 40°C, machine will work normally.	Compressor stops working, fan works at low fan speed. 10mins later, if the temperature increase to above 2°C, machine will work normally.

Safety Precautions On Servicing

Please follow these warnings when undertaking the following when servicing a dehumidifier with R290.

Checks to the area

Prior to beginning work on systems containing flammable refrigerants, safety checks are necessary to ensure that the risk of ignition is minimized. For repair to the refrigerating system, the following precautions shall be complied with prior to conducting work on the system.

Work procedure

Work shall be undertaken under a controlled procedure so as to minimize the risk of a flammable gas or vapor being present while the work is being performed.

General work area

All maintenance staff and others working in the local area shall be instructed on the nature of work being carried out. Work in confined spaces shall be avoided. The area around the workspace shall be sectioned off. Ensure that the conditions within the area have been made safe by control of flammable material.

Checking for presence of refrigerant

The area shall be checked with an appropriate refrigerant detector prior to and during work, to ensure the technician is aware of potentially flammable atmospheres. Ensure that the leak detection equipment being used is suitable for use with flammable refrigerants, i.e. no sparking, adequately sealed or intrinsically safe.

Presence of fire extinguisher

If any hot work is to be conducted on the refrigeration equipment or any associated parts, appropriate fire extinguishing equipment shall be available to hand. Have a dry powder or CO² fire extinguisher adjacent to the charging area.

No ignition sources

No person carrying out work in relation to a refrigeration system which involves exposing any pipe work that contains or has contained flammable refrigerant shall use any sources of ignition in such a manner that it may lead to the risk of fire or explosion. All possible ignition sources, including cigarette smoking, should be kept sufficiently far away from the site of installation, repairing, removing and disposal, during which flammable refrigerant can possibly be released to the surrounding space. Prior to work taking place, the area around the equipment is to be surveyed to make sure that there are no flammable hazards or ignition risks. "No Smoking" signs shall be displayed.

Ventilated area

Ensure that the area is in the open or that it is adequately ventilated before breaking into the system or conducting any hot work. A degree of ventilation shall continue during the period that the work is carried out. The ventilation should safely disperse any released refrigerant and preferably expel it externally into the atmosphere.

Safety Precautions On Servicing

Checks to the refrigeration equipment

Where electrical components are being changed, they shall be fit for the purpose and to the correct specification. At all times the manufacturer's maintenance and service guidelines shall be followed. If in doubt consult the manufacturer's technical department for assistance.

The following checks shall be applied to installations using flammable refrigerants:

- The charge size is in accordance with the room size within which the refrigerant containing parts are installed;
- The ventilation machinery and outlets are operating adequately and are not obstructed;
- If an indirect refrigerating circuit is being used, the secondary circuit shall be checked for the presence of refrigerant;
- Marking to the equipment continues to be visible and legible. Markings and signs that are illegible shall be corrected;
- refrigeration pipe or components are installed in a position where they are unlikely to be exposed to any substance which may corrode refrigerant containing components, unless the components are constructed of materials which are inherently resistant to being corroded or are suitably protected against being so corroded.

Checks to electrical devices

Repair and maintenance to electrical components shall include initial safety checks and component inspection procedures. If a fault exists that could compromise safety, then no electrical supply shall be connected to the circuit until it is satisfactorily dealt with. If the fault cannot be corrected immediately but it is necessary to continue operation, an adequate temporary solution shall be used. This shall be reported to the owner of the equipment so all parties are advised.

Initial safety checks shall include:

- those capacitors are discharged: this shall be done in a safe manner to avoid possibility of sparking;
- that there no live electrical components and wiring are exposed while charging, recovering or purging the system;
- that there is continuity of earth bonding.

Releasing refrigerant into atmosphere is strictly forbidden!

Trouble Shooting

Check the following before contacting technical support .

PROBLEM	POSSIBLE CAUSE	SOLUTION
The device does not work	The power is not connected	Insert the plug into the wall outlet
	The water tank is full	Empty the tank
	The tank has not been replaced correctly	Replace the tank
Water removal capacity is too low	Runtime is too short	Be patient, leave the unit to run for a longer period
	Ambient temperature or humidity is too low	It is normal that the device does not dehumidify in these conditions. Higher ambient temperature and humidity results in increased performance.
The device works, but reduces the relative humidity insufficiently	The room is too big	We recommend using in a smaller area or choosing a dehumidifier with a greater capacity
	There is too much ventilation	Reduce ventilation(e.g. close windows and shut doors)
	The air filter is clogged	Clean the air filter
	Set humidity is higher than the ambient humidity	Set the humidity lower than ambient humidity
Dehumidifier is blowing out warm air	The dried air is passed over heating coils before it is blown into the room as part of the dehumidifying process	This is normal, a dehumidifier is not an air cooler
The display is not showing the humidity set point	The display shows the room relative humidity not the set point	Press the humidity control button once to see the target relative humidity
Water on floor	There is residual water in tank, and the device is lurched too much by moving	Be careful when removing the tank
The dehumidifier is noisy	The air filter is blocked or the device is on an uneven surface	Clean the filter or put the device on a flat surface

Technical Specifications

Model	DYD-Y20A
Power Supply	220-240V~ 50Hz
Dehumidifying Capacity	20L/day (30°C RH80%)
	12L/day (27 °C RH60%)
Power Consumption	250W (1.50A)
Operating Temperature	5~35°C
Refrigerant	R290 (0.07kg)
Net Weight	12.2 kg
Product Size (W×D×H)	336 × 237 × 519 mm

The above technical data is indicative and for reference only. Some variation may exist between batches.

Compliance

This appliance has been fully tested and meets all requirements as set out by standards AS/NZS 60335.1 and AS/NZS 60335.2.40.



Responsible disposal

- At the end of its working life, make the appliance unserviceable by unplugging it from the power outlet and cutting the power cord.
- Do not throw this appliance out with your household rubbish. Electrical and electronic products contain substances which can have a detrimental effect on the environment and human health if disposed of inappropriately. Observe any local regulations regarding the disposal of electrical consumer goods and dispose of it appropriately for recycling. Contact your local authorities for advice on recycling facilities in your area.



living & co.

We pride ourselves on producing a range of quality home appliances that are both packed with features and completely reliable. We are so confident in our products, we back them up with a 2 year warranty
Now you too can relax knowing that you are covered.

Customer Helpline NZ:0800 422 274

This Product is covered by 2 year warranty when accompanied by proof of purchase.

IM Version 1.0 - Oct 2023