

# living & co.

## BASE CABINET 2 DOOR

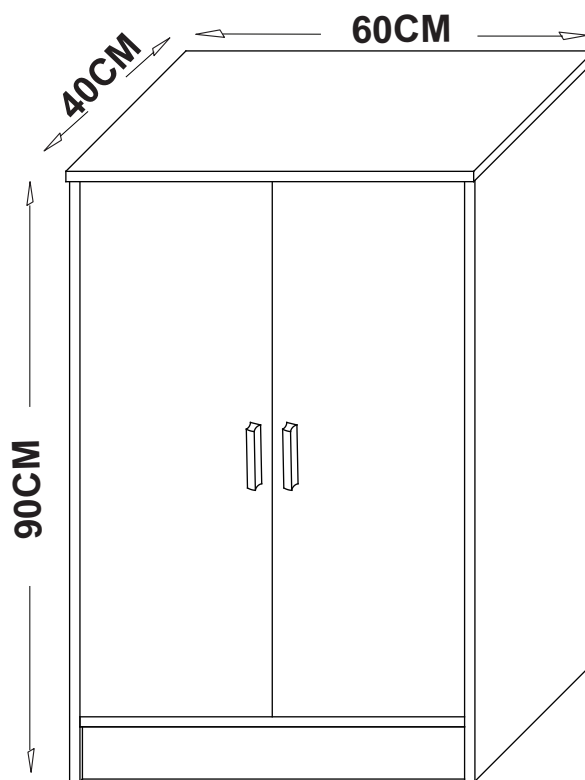

### INSTRUCTION MANUAL

MAXIMUM WEIGHT :10KG PER SHELF

---

AFTER SALES SUPPORT

  0800 422 274



## Important Safety Instructions

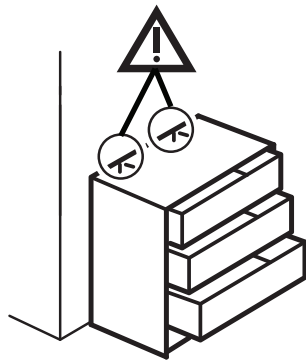

Serious or fatal crushing injuries can occur from furniture tipping over. Use of tip over restraints may reduce, but not eliminate the risk of tip over. To help prevent tip over:

- Place heaviest items in the bottom drawers.
- Unless specifically designed to accommodate, do not set TVs or other heavy objects on top of this product.
- Never allow children to climb or hang off of drawers, doors or shelves.
- Never open more than one drawer at a time.

## Assembly Details

**30** mins

Approximate Assembly Time

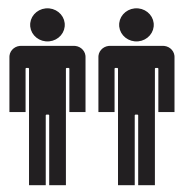

2 person assembly

Floor Area:

**2x2** meters



Required Assembly Space

Phillips-Head Screwdriver



Required Assembly Tools











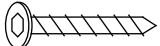
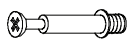



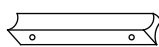
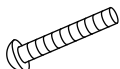

## Tips Before you Start

1. Please check that all parts are present before you start the assembly of your furniture.
2. For ease and speed of assembly, we recommend that before you commence each step of the assembly, that you identify all the parts required for that step.
3. For larger items, please ensure that you have sufficient space and people (as indicated on page 1) to assemble your product safely.
4. We recommend that, where possible, all items are assembled near to the area in which they will be placed in use, to avoid moving the product unnecessarily once assembled.
5. For the protection of your furniture, we recommend that the product is placed on a protected surface during assembly to prevent any damage.
6. During assembly please take care not to over-tighten any fittings, this may damage the product. Do not use power tools.
7. Always place the product on a flat, steady and stable surface.
8. Do not stand on the product. Do not use the product as a step ladder.
9. This product is intended for indoor, household use only as it is a non-industrial product.
10. Please use caution and care when lifting the product to avoid personal injury and/or product damage.

## Care and Maintenance

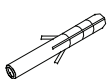
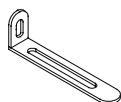
- ✓ Please periodically check all things and re-tighten as necessary.
- ✓ To clean your item, please use a damp cloth and wipe clean.
- ✓ Never allow any kind of liquid to remain on your furniture. Absorption can cause wood to warp or finishes to de-laminate.
- ✓ Please do not place hot items (eg. hot drinks) directly on to the surface.
- ✓ Please do not drag and pull your furniture.

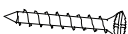
# Hardware List

<p>P1X12</p>  <p>M5x40mm</p>	<p>P2X4</p>  <p>Ø5mmx35mm</p>	<p>P3X4</p>  <p>14.7mmx11mm</p>	<p>P4X1</p> 	<p>P5X2</p>  <p>M3x14mm</p>
<p>P6X2</p> 	<p>P7X2</p>  <p>M3x8mm</p>	<p>P8X2</p> 	<p>P9X4</p>  <p>M4x14mm</p>	<p>P10X4</p> 
<p>P11X4</p> 	<p>P12X12</p> 	<p>P13X4</p> 	<p>P14X1</p> 	<p>P15X1</p> 
<p>P16X2</p> 	<p>P17X2</p> 	<p>P18X2</p>  <p>M5x12mm</p>	<p>P19X2</p>  <p>M4x35mm</p>	<p>Tools required</p>   <p>Phillips screwdriver    Hammer</p>

# Parts List

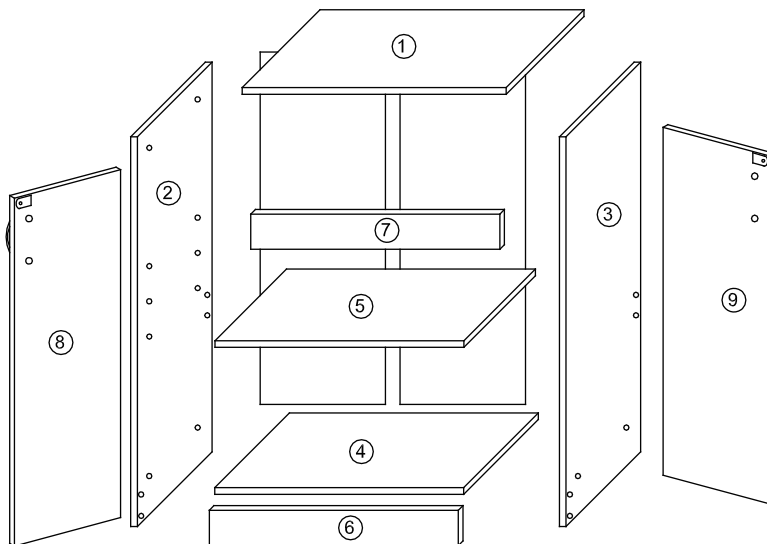

# Assembly

## STEP 1

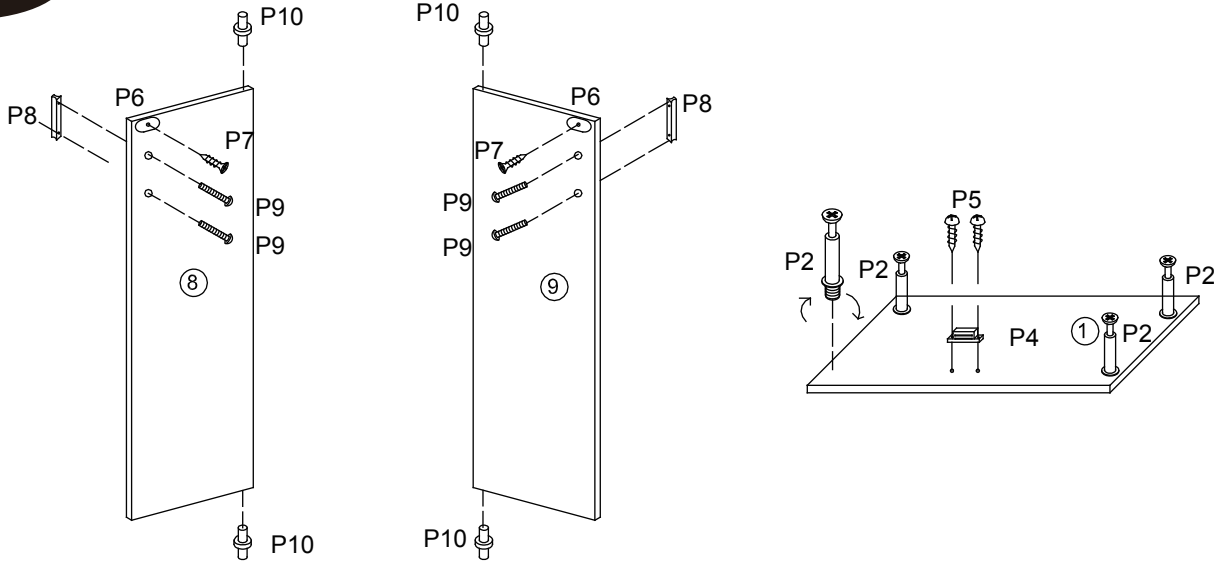

## STEP 2

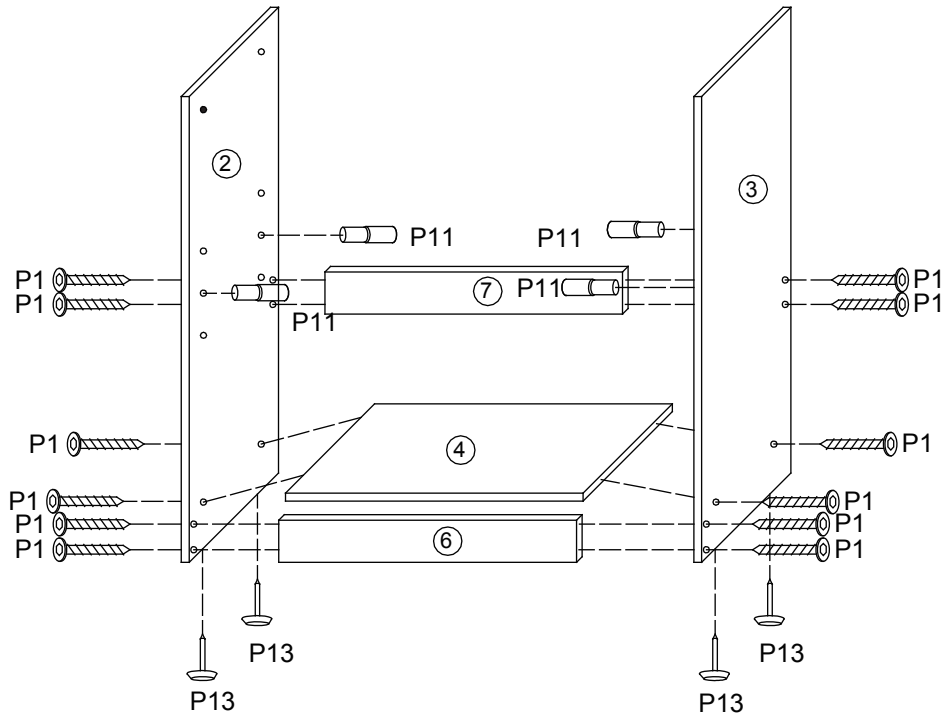

# Assembly

## STEP 3

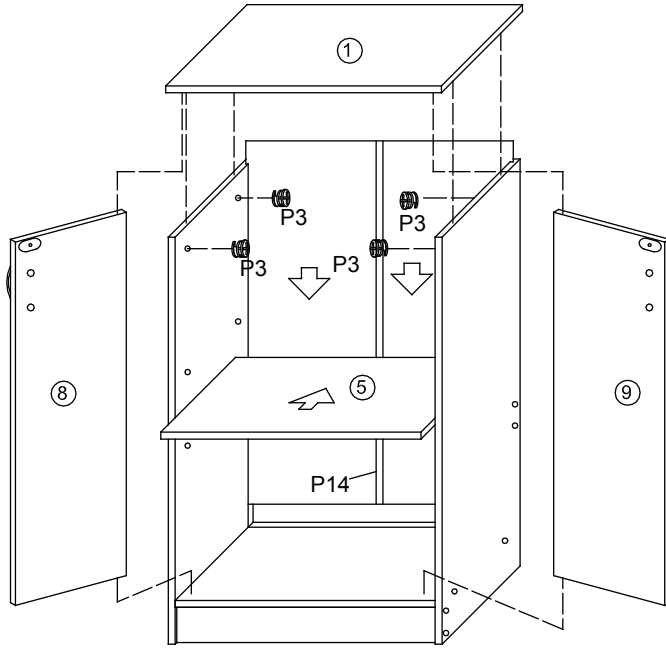

## STEP 4

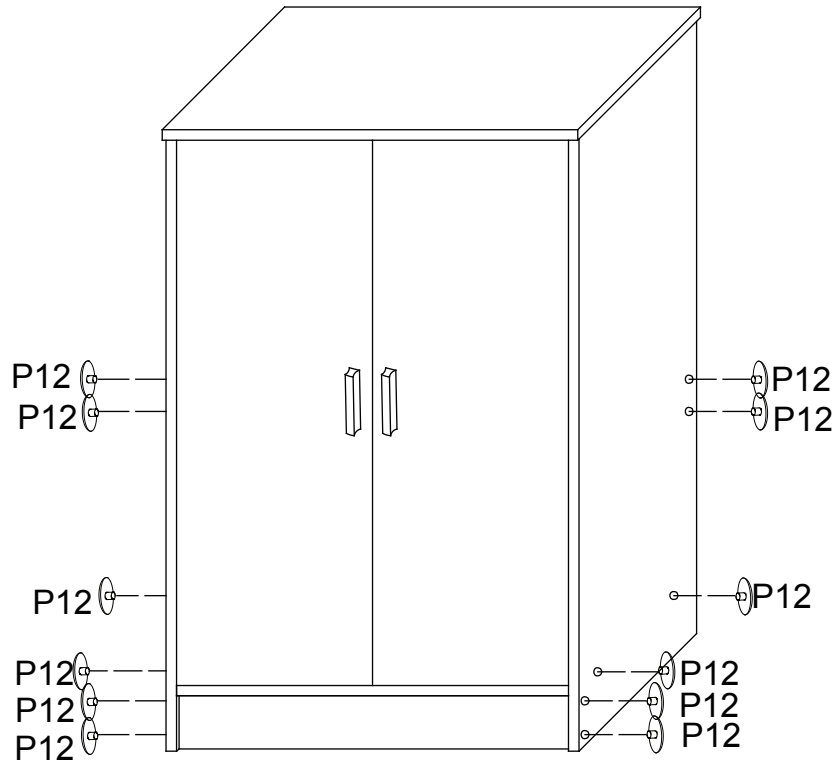

# Assembly

## STEP 5

### BE HOME SAFE

Fixtures for anti-tipping have been supplied with your product  
To prevent injury or household damage  
Always fix drawers, shelving, free  
standing cupboards, and other upright  
furniture to the wall

More information:  
[www.eqc.govt.nz/fixfasten](http://www.eqc.govt.nz/fixfasten)

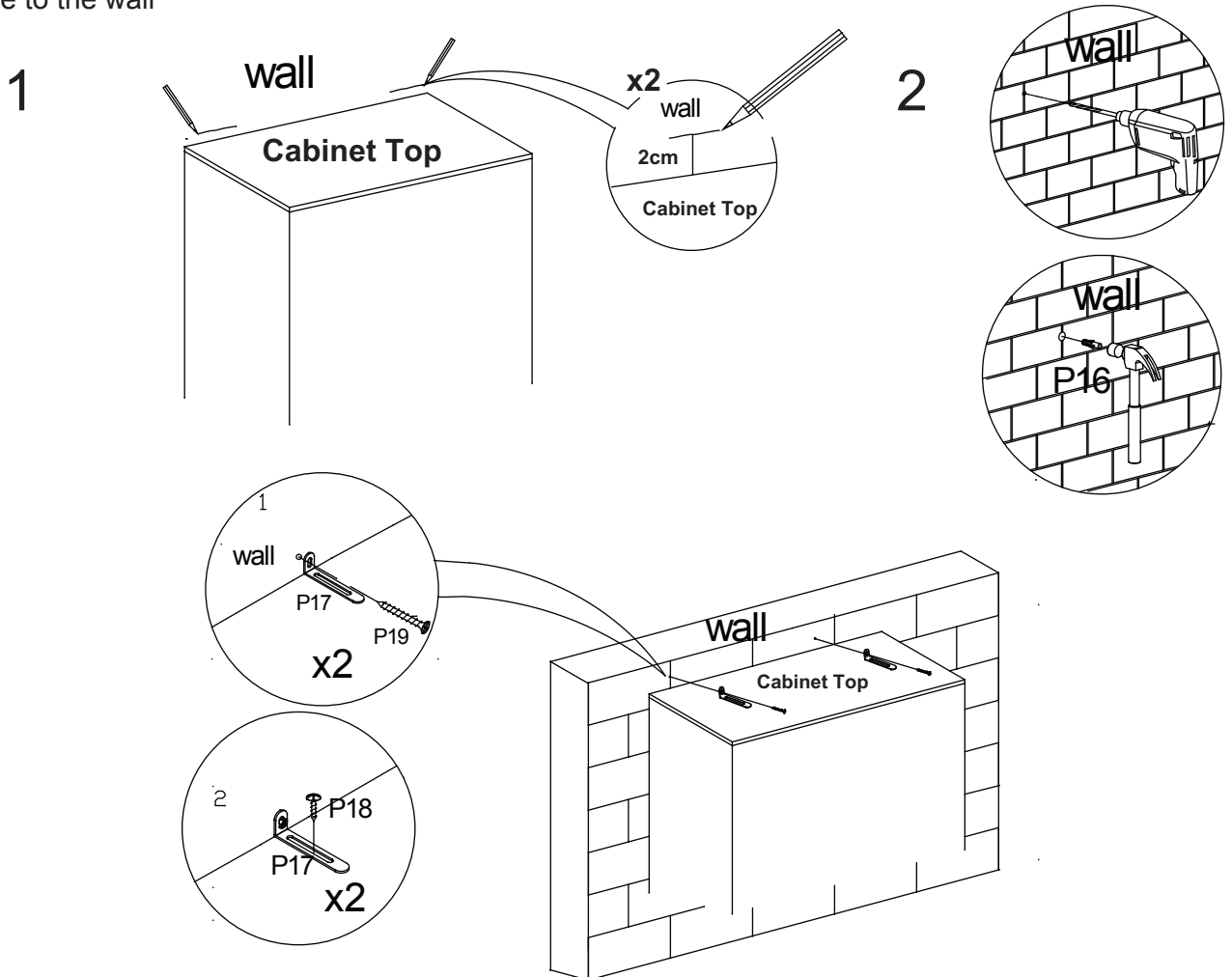





**living & co.**

### **Warranty**

We pride ourselves on producing a range of quality products that are both packed with features and completely reliable. We are so confident in our products, we back them up with a one-year warranty. Now you too can relax knowing that you are covered.

Customer Helpline NZ: 0800 422 274  
This product is covered by 1 year warranty  
when accompanied by proof of purchase.

---

**AFTER SALES SUPPORT**

  0800 422 274