

living & co.

BROOM CABINET 2 DOOR

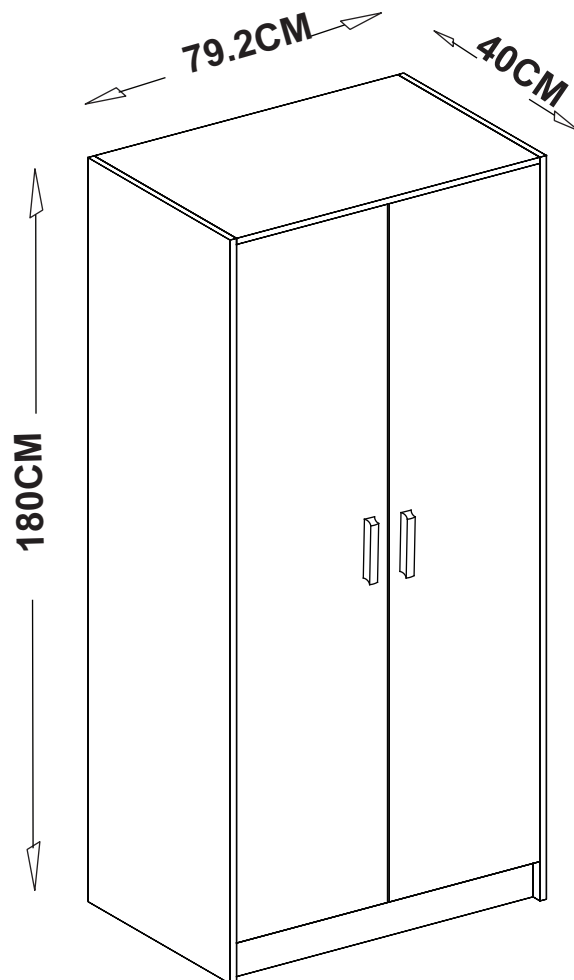

INSTRUCTION MANUAL

MAXIMUM WEIGHT :10KG PER SHELF

AFTER SALES SUPPORT

  0800 422 274

Important Safety Instructions

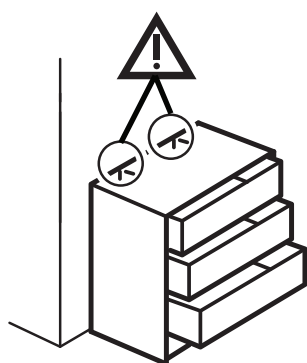

Serious or fatal crushing injuries can occur from furniture tipping over. Use of tip over restraints may reduce, but not eliminate the risk of tip over. To help prevent tip over:

- Place heaviest items in the bottom drawers.
- Unless specifically designed to accommodate, do not set TVs or other heavy objects on top of this product.
- Never allow children to climb or hang off of drawers, doors or shelves.
- Never open more than one drawer at a time.

Assembly Details

40 mins

Approximate Assembly Time

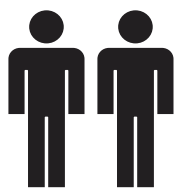

2 person assembly

Floor Area:

3x3 meters



Required Assembly Space

Phillips-Head Screwdriver



Required Assembly Tools











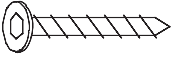
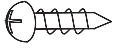



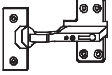

Tips Before you Start

1. Please check that all parts are present before you start the assembly of your furniture.
2. For ease and speed of assembly, we recommend that before you commence each step of the assembly, that you identify all the parts required for that step.
3. For larger items, please ensure that you have sufficient space and people (as indicated on page 1) to assemble your product safely.
4. We recommend that, where possible, all items are assembled near to the area in which they will be placed in use, to avoid moving the product unnecessarily once assembled.
5. For the protection of your furniture, we recommend that the product is placed on a protected surface during assembly to prevent any damage.
6. During assembly please take care not to over-tighten any fittings, this may damage the product. Do not use power tools.
7. Always place the product on a flat, steady and stable surface.
8. Do not stand on the product. Do not use the product as a step ladder.
9. This product is intended for indoor, household use only as it is a non-industrial product.
10. Please use caution and care when lifting the product to avoid personal injury and/or product damage.

Care and Maintenance

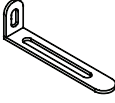
- ✓ Please periodically check all things and re-tighten as necessary.
- ✓ To clean your item, please use a damp cloth and wipe clean.
- ✓ Never allow any kind of liquid to remain on your furniture. Absorption can cause wood to warp or finishes to de-laminate.
- ✓ Please do not place hot items (eg. hot drinks) directly on to the surface.
- ✓ Please do not drag and pull your furniture.

Hardware List

<p>P1X24</p>  <p>5mmx40mm</p>	<p>P2X36</p>  <p>4mmx12mm</p>	<p>P3X4</p> 	<p>P4X2</p>  <p>M4x18mm</p> 	<p>P5X6</p> 
<p>P6X26</p> 	<p>P7X6</p> 	<p>P8X24</p> 	<p>P9X1</p> 	<p>P10X8</p> 
<p>P11X6</p>  <p>M3.5x12mm</p>	<p>P12X2</p>  <p>M4x35mm</p>	<p>P13X2</p> 	<p>P14X2</p> 	<p>P15X2</p>  <p>M5x12mm</p>
<p>Tools required</p>  <p>Phillips screwdriver</p>  <p>Hammer</p>				

Parts List

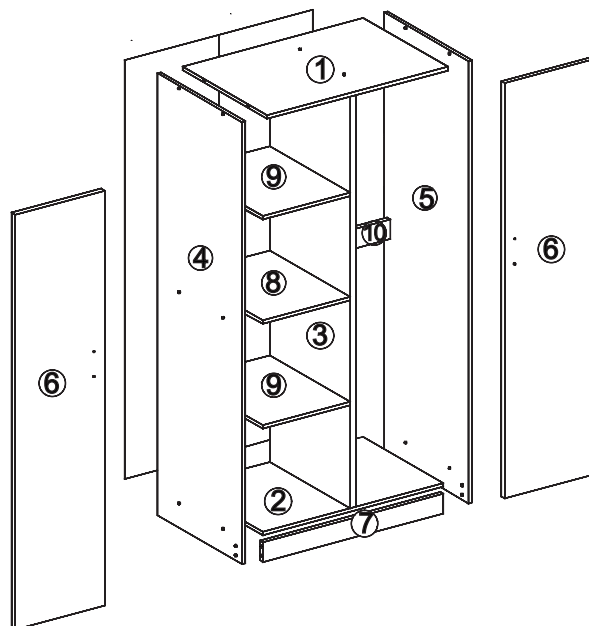

Assembly

STEP 1

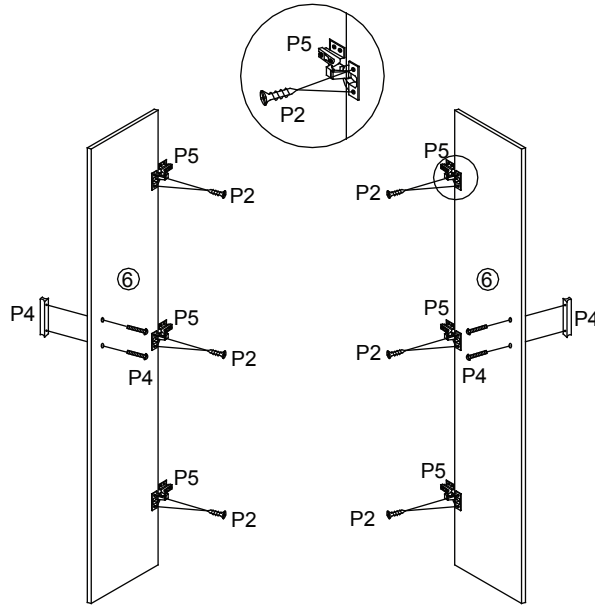

STEP 2

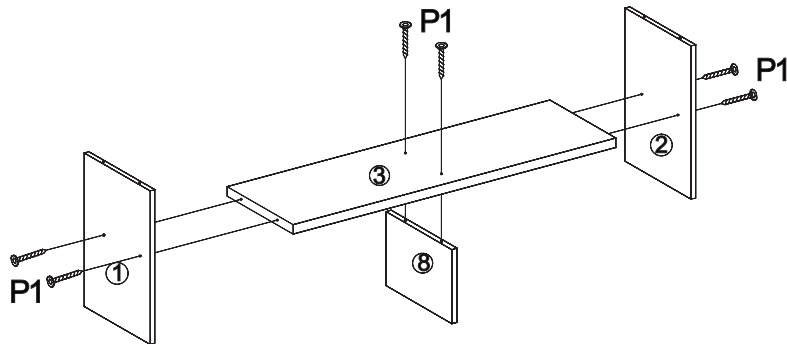

STEP 3

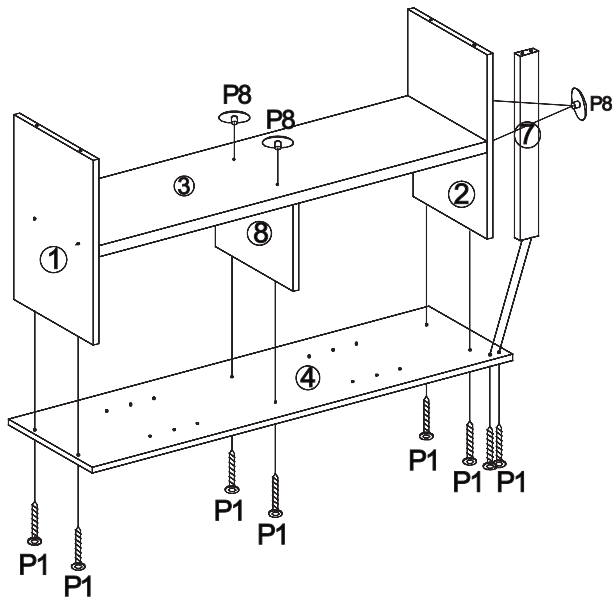

Assembly

STEP 4

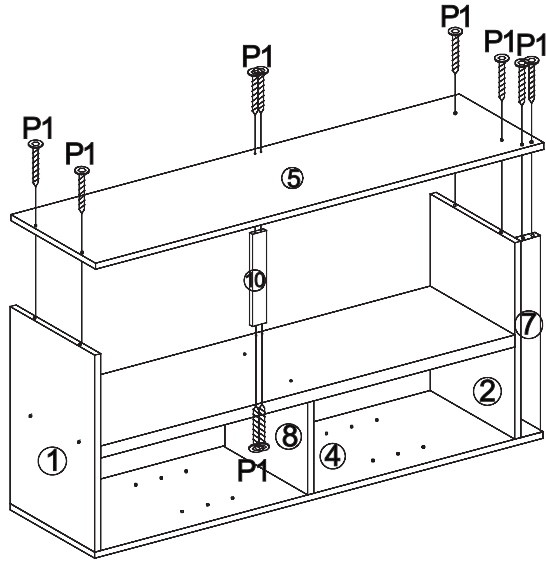

STEP 5

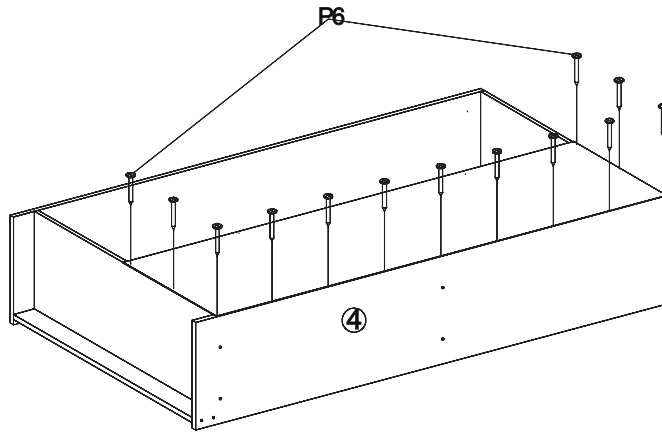

STEP 6

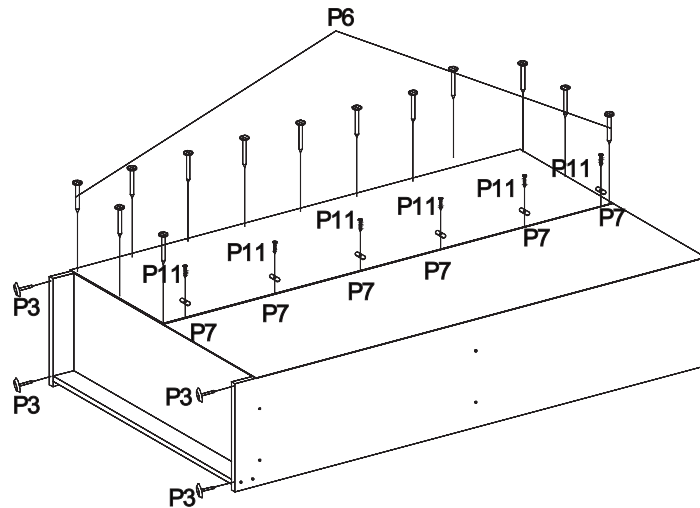

Assembly

STEP 7

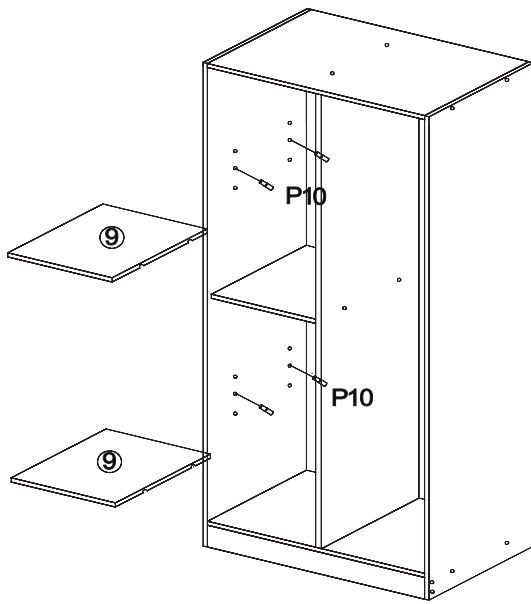

STEP 8

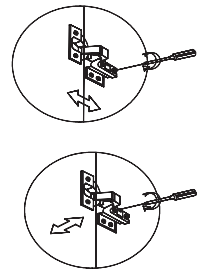
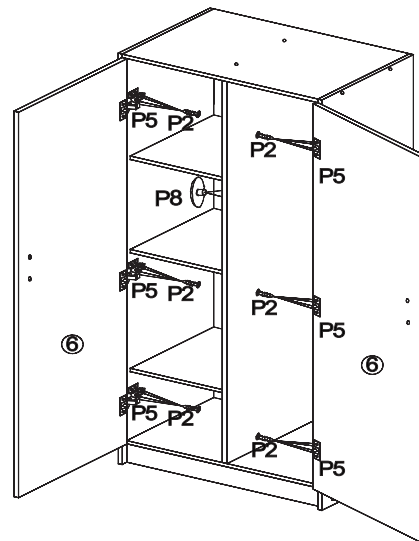

STEP 9

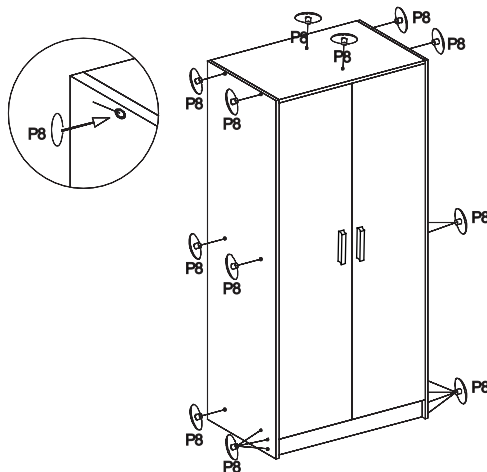

Assembly

STEP 10

How to adjust your doors to make the gaps more even.

Height Adjustment

Loosen the top and bottom screws and adjust the door placement. When finished tighten the screw

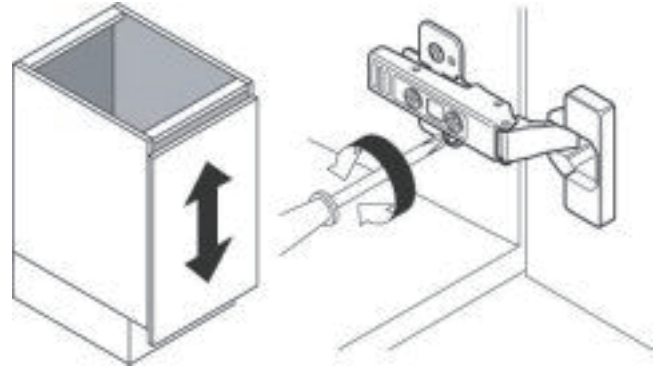

Depth Adjustment

Loosen the rear screw and adjust the door placement. When finished tighten the screw

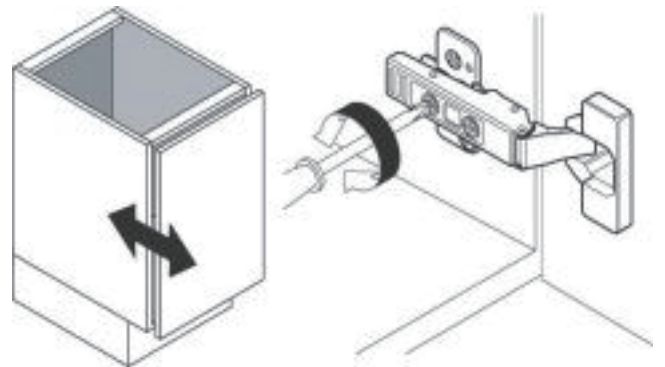

Gap adjustment between doors

Loosen or tighten the front screw to adjust the gap between the two doors.

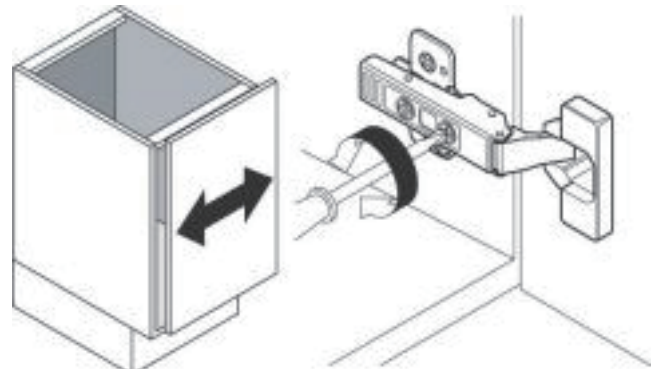

Assembly

STEP 11

BE HOME SAFE

Fixtures for anti-tipping have been supplied with your product
 To prevent injury or household damage
 Always fix drawers, shelving, free
 standing cupboards, and other upright
 furniture to the wall

More information:
www.eqc.govt.nz/fixfasten

1

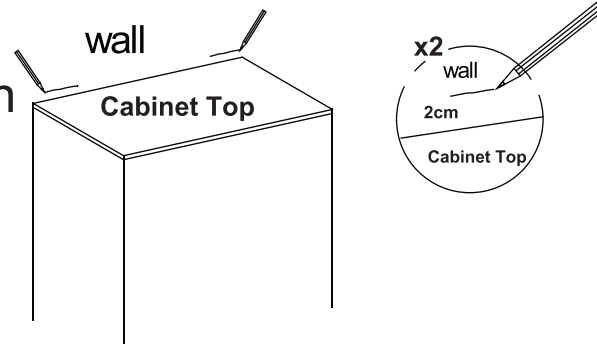

2

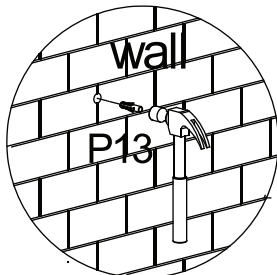
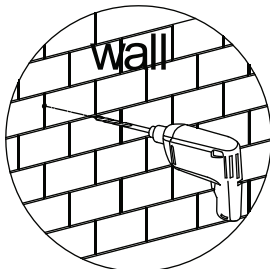

3

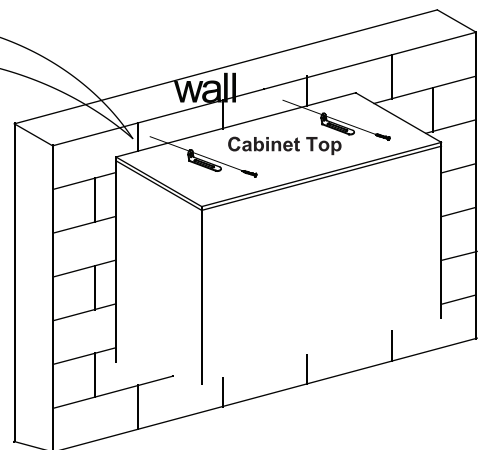
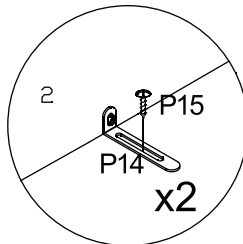
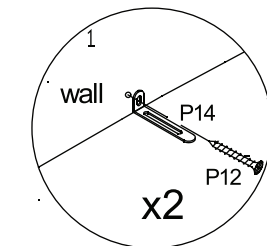



living & co.

Warranty

We pride ourselves on producing a range of quality products that are both packed with features and completely reliable. We are so confident in our products, we back them up with a one-year warranty. Now you too can relax knowing that you are covered.

Customer Helpline NZ: 0800 422 274
This product is covered by 1 year warranty
when accompanied by proof of purchase.

AFTER SALES SUPPORT

  0800 422 274